UNIQUE®

2245 Wycroft Road #5, Oakville, Ontario Canada L6L 5L7
Ph: 905-827-6157 Toll Free: 1-877-427-2266 Fax: 905-827-2027
www.UniqueOffGrid.com

Owners Manual - Current

LGP 15



"Personal Service & Knowledge makes us Unique"

UNIQUE UGP-15

Propane Refrigerator Installation and Owners Manual



WARNING: *Improper installation, adjustment, alteration, service or maintenance can cause injury or property damage. Refer to this manual. For assistance or additional information consult a qualified installer, service agency or the gas supplier.*

!SAVE THESE INSTRUCTIONS!

FOR YOUR SAFETY IF YOU SMELL GAS

*Open windows.
Do not touch electrical switches.
Extinguish any open flame
Immediately turn off gas supply and call your gas supplier*

FOR YOUR SAFETY

Do not store or use gasoline or other flammable and liquids in the vicinity of this or any other appliance



The installation of the appliance must conform with local codes or, in the absence of local national Fuel Gas Code, ANSI Z233.1 and in Canada B149.2 Propane Storage and Handling Code





NOTICE TO INSTALLER/CUSTOMER

Please read carefully before hook-up!

1. The dwelling must have an adequate air supply and access to fresh air/oxygen in order to operate safely. Propane fridges/freezers, like any other gas appliance, must have access to fresh air/oxygen. **This unvented appliance must not be used in an airtight application.**
2. This refrigerator must be installed by a licensed gas fitter.
3. The propane gas supply pressure regulator must be set at 11" water column.
4. The left side heat shield (facing front of the refrigerator) must be installed. The heat shield is shipped in the refrigerator carton.
5. For safety & efficient operation the proper clearances on all sides and top must be maintained. The clearances are listed in the Owner's Manual.
6. For proper and efficient operation the refrigerator must be level, both side to side and front to back (use bubble type level).
7. The Combination Carbon Monoxide (CO) Alarm & Safety Shut-Off must be installed and connected (CM Models only) with the Alarm mounted as indicated in the Carbon Monoxide Alarm (Monitor) Installation Manual.

NOTE: It is illegal to operate this refrigerator in Canada without the Combination Carbon Monoxide Alarm & Safety Shut-Off installed, and will void the Canadian Standards Association Certification. Non compliance will void the Canadian certification and void household/cottage insurance coverage. This refrigerator vents combustion products directly into the living space. The CO Alarming Device with Safety Shut-Off has been added to this refrigerator to guard against potentially high levels of Carbon Monoxide, which can kill you. Once unsafe levels of CO are detected, an alarm will sound and the refrigerator will be shut off.

WARNING: Actuation of this device indicates the presence of unsafe levels of carbon monoxide (CO) which can KILL YOU. If alarm signal sounds:

- a. Immediately move to fresh air --- outdoors or by an open door or window. Check that all persons are accounted for. Do not re-enter the premises or move away from the open door/window until the emergency services responders have arrived, the premises have been aired out, and your alarm remains in its normal condition;
- b. Call emergency local service telephone number, fire department or 911.
- c. The following symptoms may be related to CARBON MONOXIDE POISONING and should be discussed with ALL members of the household:

Mild Exposure: Headaches, running nose, sore eyes, often described as "flu"-like symptoms;

Medium Exposure: Dizziness, drowsiness, vomiting;

Extreme Exposure: Unconscious, brain damage, death.

- d. Read the Instructions for complete Information on Alarms Signals.

8. NOTE: The Combination Carbon Monoxide Alarm & Safety Shut-Off Instructions (CM Model), battery, Owners/Installation Manual are stored inside the refrigerator.

For Unique Gas Products Support, Call Toll Free 1-877-427-2266

9. Regular maintenance of the fridge is critical to prevent unsafe levels of Carbon Monoxide. Before lighting the refrigerator at any time, clean the flue tube as per the Owner's Manual & make sure the burner and areas around the burner are free from any lint, spider webs or any other debris. Please record your appliance maintenance on the SERVICE RECORD label located at the back of your appliance.

WARNING -- Test the Combination Carbon Monoxide & Safety Shut-Off device operation after the refrigerator has been in storage, before each start up , and at least once per week during use.

UNIQUE

MANUFACTURED AND CERTIFIED BY

Unique Gas Products Ltd

"Personal Service & Knowledge makes us Unique"

2245 Wycroft Road #5
Oakville, Ontario Canada L6L 5L7
Ph: 905-827-6154 Toll Free: 1-877-427-2266 Fax: 905-827-2027
www.UniqueOffGrid.com
E-mail: info@uniqueoffgrid.com

Table of Contents

Chapters

Welcome	1
Safety and Warnings	1
Appliance Installation	2
General Operating Instructions	3
How To Use The Refrigerator	3
Maintenance & Service	4
Troubleshooting & Suggested Spares	5
Carbon Monoxide Instructions (CM Model)	6
Door Reversal and Removal Instructions	7
Temperature Controls & Food Storage and Cleaning	8
Parts & Warranty	9

Welcome & Congratulations

Congratulations on your purchase of a **UNIQUE** refrigerator!. We are very proud of our product and we are completely committed to providing you with the best service possible. Your satisfaction is our #1 priority. Please read this Manual very carefully. It contains valuable information on how to properly maintain your new gas refrigerator.

We know you will enjoy your new refrigerator and Thank You for choosing one of our Unique Gas Products. We hope you will consider us for future purchases.

PLEASE READ AND SAVE THESE INSTRUCTIONS

This manual provides specific operation instructions for your model. Use your refrigerator only as instructed in this manual. These instructions are not meant to cover every possible condition and situation that may occur. Common sense and caution must be practiced when installing, operating and maintaining the appliance

Please record your model and serial # shown below for future reference. This information is found on your CSA rating/serial plate inside the refrigerator compartment.

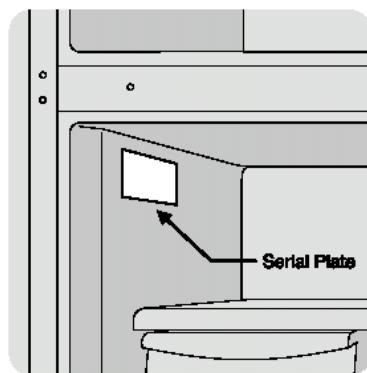

Please mail in the **Warranty Registration Card** included with you refrigerator.



Safety and Warnings

If you smell gas

- Open Windows
- Don't touch electrical switches
- Extinguish any open flame
- Immediately call your gas supplier

For you Safety

- Due to the potential of carbon monoxide (CO) from many different sources inside your dwelling, and to meet most building codes, the dwelling must have a separate wall-mounted CO alarming device. This is beyond and safety devices/construction inherent to the Unique appliance.
- Do not store or use gasoline or other flammable vapors and liquids in the vicinity of this unit or any other appliance

Warning

- Improper installation, adjustment, alteration, service or maintenance can cause injury or property damage. Refer to this manual. For assistance or additional information consult a qualified installer, service agency or the gas supplier.
- This product can produce Carbon Monoxide. Carbon Monoxide has no odour and can kill you. The burner and flue system must be kept clean. See owner's manual for cleaning instructions.

Installation Instructions

- The installation of the appliance must conform with local codes or, in the absence of local national Fuel Gas Code, ANSI Z233.1 and in Canada B149.2



Installation

For best performance at high ambient temperatures, there must be free air circulation over the cooling unit at the rear of the refrigerator.

Ensure that there is a free air space above the refrigerator and that the flue (chimney) on top of the cabinet is not covered in any way. Do not place the refrigerator in a space where air circulation is restricted. Follow “clearance” instructions.

This free-standing refrigerator requires accessibility to the back for servicing the gas equipment, which can be obtained by using a certified Flexible Metal Connector to allow the refrigerator to be withdrawn without disrupting the gas supply. “Where a flexible metal connector is used, it must comply with local authorities and in Canada with the provisions of the current Standard CAN 1-6.10, Metal Connectors For Gas Appliances”. However, if the Local Authorities require a rigid gas supply connector, the refrigerator should be located with sufficient space at the back for servicing or, if located against a wall a removable panel of a minimum size of 16” x 20” should be provided in the wall to allow access to the rear of the refrigerator. If you purchased a CM (CO Monitor model) you must follow instructions in Section 6 - 5.0 onward.

Heat Shield

The heat shield must be installed before operating the appliance. This is a CSA requirement.

Un-wrap the heat shield (located inside the box along with the appliance). Mount heat shield with the screws (supplied) to left side of the fridge. See diagram.

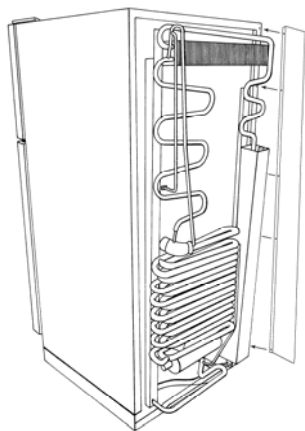

Heat Shield

Clearances

Minimum clearances to combustibile materials are:

Top – 10”

Sides – 2”

Rear – 1” with left hand side rear sheild mounted
as shown in Figures. 1, 2 & 3.

Note: DO NOT install the appliance directly on carpeting. Carpeting must be removed or protected by a metal or wood panel beneath the appliance, which extends at least the full width and depth of the appliance.

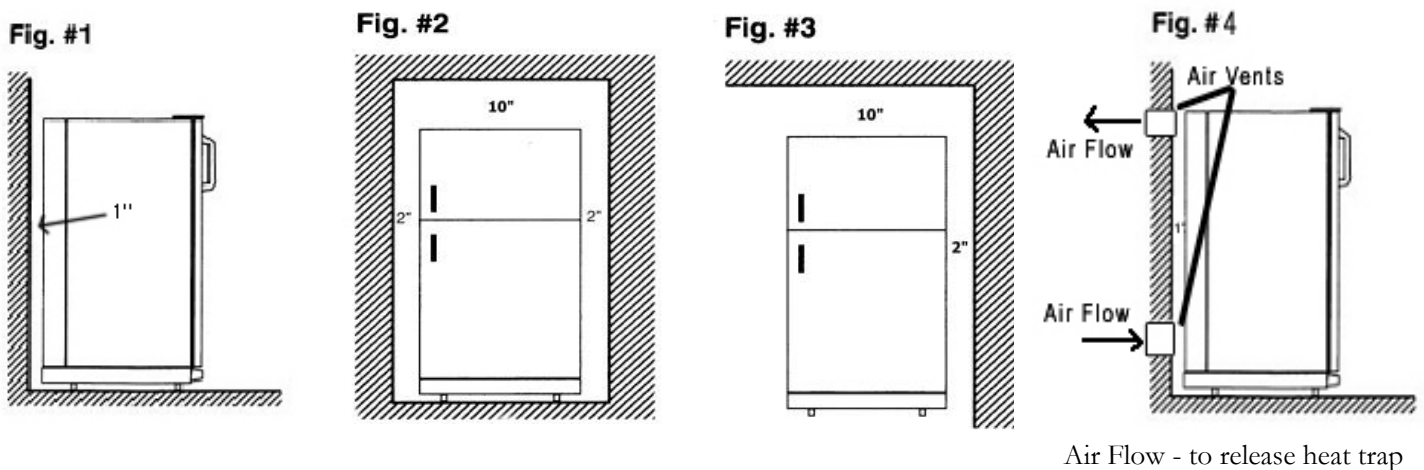

- Fig#1 - This is ideal as both top and sides are open
- Fig#2 – During hot/humid weather this confined area will become very warm. To reduce heat build-up, we recommend providing an area for two air vents to circulate the air. One placed 6” off the floor and the other at or above the appliance top. Cold air return vents with adjustable louvers, works very well. This will allow hot air to evacuate the area and assist in air flow across the fins (similar to air passing across a radiator) – **See Fig #4**
- Fig#3 – If this is your opening you only need to stay the diagramed distance from the wall and ceiling. There is no need for additional venting.

Gas Connection

Hook-up to the gas supply line: 3/8" SAE (UNF 5/8" - 18) male flare connection. A backup wrench must be used when tightening gas supply fitting. All completed connections should be checked for leaks with a non-corrosive leak detector and/or soap and water for a bubble check..



WARNING – DO NOT USE FLAME TO CHECK FOR GAS LEAKS

The gas supply system must incorporate a pressure regulator to maintain a supply pressure of not more than 12" water column and no less than 11" water column. (max setting)

Make sure the refrigerator and any other high BTU appliances on your line are turned on when checking the gas pressure. The appliance and its individual shut-off valve must be disconnected from the gas supply piping system during any pressure testing of that system at pressures in excess of 1/2" psig.

In case detailed instructions on the installation and connection of the gas supply are required, contact your dealer or distributor.

Leveling

Ensure the fridge is level by using a 2ft level. This is accomplished by adjusting the feet at the front, underneath the fridge.

General Operating Instructions

Importance of Leveling a Refrigerator

The refrigerator must be adjusted to a vertical position in both directions. In an absorption refrigeration system, ammonia is liquefied in the finned condenser coil at the top rear of the refrigerator. The liquid ammonia then flows into the Evaporator (inside the freezer section) and is exposed to circulating flow of hydrogen gas, which causes the ammonia to evaporate, creating a cold condition in the freezer.

When starting this refrigerator for the very first time, the cooling cycle may require up to four hours of running time before the cooling unit is fully operational to begin slowly loading compartment.

The tubing in the evaporator section is specifically sloped to provide a continuous movement of liquid ammonia, flowing downward by gravity through this section. If the refrigerator is operated when not level, liquid ammonia will accumulate in sections of the evaporator tubing. This will slow the circulation of hydrogen and ammonia gas, or in severe cases, completely block it, resulting in a loss of cooling. Warranty will not cover recharge/rebuild if caused by not running the fridge level.

This refrigerator operates only on LP Gas (Propane)

Note: After changing an LP tank, or after a long shut off period, the gas line is likely to be filled with air. You may have to repeat the lighting procedure several times to purge the air out of the gas lines. We suggest first turning off gas at the control panel, then the tank, this will reduce an air trap in the gas line.

Gas Operation

“Start Up” Procedure – see figure # 5 on next page for control panel

1. Locate the control panel below the bottom of the fridge door, behind the plastic grill, pull off plastic grill to access controls.
2. Turn the gas shut off valve **C** to the ON position – to the left

3. Turn thermostat button **B** fully clockwise (max), start to spark igniter button **A** before depressing the gas control button **E**, there may be a period of time required for air to escape from the gas line and flow up to burner. **Length of time will vary depending on distance of the fridge to propane tank.** Continue pushing the igniter button while holding in the gas button until the needle in the flame indicator **D** moves into the green area (to the right).
4. When the needle starts to move into the green area, this means flame is now lit. Stop sparking and continue to hold gas button **E** down for an additional 10 seconds. Release gas button, fridge should now stay lit and needle remains in the green area.
5. Once all the above has been done and you are ready to re-start your fridge for use, leave the thermostat button at **"4"**. Setting the thermostat to **"4"** will allow the fridge to get to optimum cooling temperature. It may be necessary to adjust the temperature control on the thermostat knob to suit your needs.
6. The quantity of food in the refrigerator, the frequency with which the refrigerator doors are opened and the room temperature will all affect refrigerator temperatures.

“Shut Down” Procedure

1. Turn knob C to Gas “Off” position – to the right.

Note: If using CO-Monitor , the monitor must be hooked up and be reset with the battery installed for the flame to stay on – Refer to Chapter 6

CONTROLS – See Fig 5. for description of controls

Figure #5

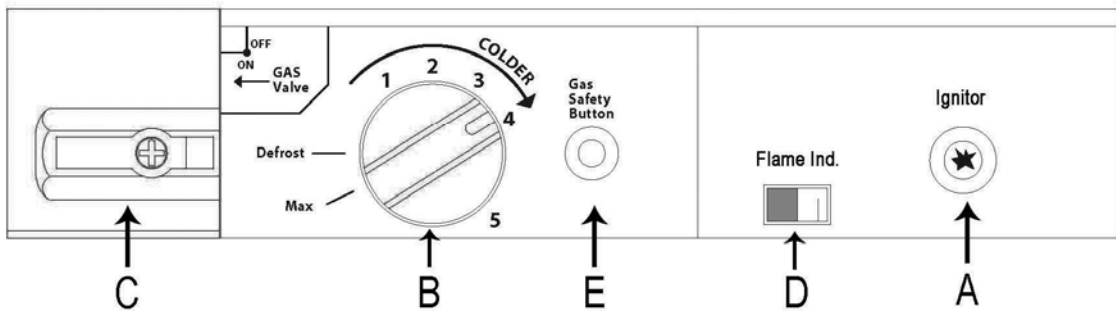

Thermostat

A thermostat controls the refrigerator cooling temperature; it can be adjusted by turning knob **B** to different settings to maintain the desired refrigerator temperature. Knob **E** also incorporates a safety device, which automatically shuts off the supply of gas if the flame goes out. The piezo electric igniter discharges sparks onto the burner when the button is pushed.

1. **“DEF” Defrost Setting on the Gas Thermostat:** In gas operation, the thermostat closes its main valve and the burner runs continuously at the bypass rate or pilot flame.(turn counter clockwise)
2. **“MAX” Setting of the Thermostat:** In gas operation, the thermostat allows the burner to remain on high flame continuously. (turn clockwise)
3. The thermostat can be adjusted between “Max” and “Defrost” to obtain the desired fridge temperature.

When the thermostat reaches the set temperature, it will cut the burner back to bypass operation.

The setting of the thermostat is critical and recommend it be adjusted to maintain a dry frost on the cooling fins (approx 38° Freinhight or 3° Celcius) . Adjust the thermostat knob closer to “Max” (clockwise) when the outside temperature rises.

How To Use The Refrigerator

FOOD STORAGE COMPARTMENT

The food storage compartment is completely closed and unventilated, which is necessary to maintain the required low temperature for food storage. The coldest areas in the refrigerator are under the cooling fins and at the bottom of the refrigerator. The warmer areas are on the upper door shelves. This should be considered when placing different types of food in the refrigerator.

FROZEN FOOD STORAGE COMPARTMENT

Quick frozen soft fruits and ice cream should be placed in the coldest part of the compartment which is at the bottom of the aluminum liner. Frozen vegetables, may be stored in any part of the compartment.

This compartment is not designed for deep or quick freezing of food. Meat or fish, whether raw or prepared, can be stored in the frozen food storage compartment provided they are pre-cooled in the refrigerator. To prevent food from drying out, keep it in covered dishes, containers, plastic bags or wrapped in aluminum foil.

Defrosting

Frost will gradually accumulate inside the refrigerator and freezer surfaces. It must not be allowed to grow too thick as it acts as an insulator and adversely affects the refrigerator performance. Check the formation of frost every week and when it exceeds 3/8" thick, defrost the refrigerator. It will not hurt the fridge to have the ice buildup, if it gets too thick with will act as an insulator and hamper the cooling ability of the fridge.

Defrosting can be done with the fridge running if so desired. Simply open both doors and turn thermostat to min, or fully counter clockwise. Once the ice starts to melt a towel can be placed under the evaporator fins in the fridge, then pull off the ice. Wipe the fins clean and shut both doors. For the freezer, defrosting time can be reduced by filling a tray with hot water and placing it in the freezer compartment, again wipe clean with a towel once melted.



DO NOT USE A HOT AIR BLOWER, PERMANENT DAMAGE COULD RESULT, DO NOT USE A KNIFE, AN ICE PICK, OR ANY OTHER SHARP TOOLS TO REMOVE FROST FROM THE FREEZER COMPARTMENT.



FRIDGE SECTION

Inside the refrigerator compartment, the defrost water runs from a collector channel to a drip tray/cup at the rear of the refrigerator where it normally evaporates. If heavy frost has built up on the cooling fins creating a lot of defrost water, Beware your water reservoir may overflow, we suggest you inspect reservoir before/after cycle.

FREEZER SECTION

This area must be wiped down with cloths to remove water after defrosting; there is no drain for this compartment

Note: When all frost has melted in the freezer compartment & interior of the refrigerator it should be wiped up with a clean cloth. Set the thermostat to its max position until desired interior temperature has been achieved, approx 4 plus hrs dependant on room temperature, and then replace all food.

Cleaning

Cleaning the refrigerator is usually done after it is defrosted or put into storage. To clean the interior liner of the refrigerator, use lukewarm weak soda solution. Use only warm water to clean the finned evaporator, gasket, ice trays and shelves.



Never use strong chemicals or abrasives to clean these parts as the protective surfaces will be damaged. It is important to always keep the refrigerator clean. Dishwasher detergent is recommended

Interior Light

The interior light is located inside the fridge compartment at the top. You can replace it by unscrewing counter clockwise. Four “D” size batteries operate the interior light, the battery compartment is located on the exterior back of the fridge, upper right side while facing the back of the fridge.

Shut Down Procedure

- A. Turn gas valve knob “C” to the “off” position
- B. If the refrigerator will not be in operation for a period of weeks, it should be emptied, defrosted, cleaned and the doors left open. The ice tray should also be dried and kept outside the cabinet, also turn off gas at gas control then the main supply source.

Maintenance & Service

The user should be aware of service that must be done on a regular schedule to keep the refrigerator operating properly. Installation must be by a licensed gas fitter in accordance with local codes or in the absence of local national Fuel Gas Code, ANSI Z233.1 and in Canada B149.2 Propane Storage and Handling Code (latest edition).

REFRIGERATOR REMOVAL

Before working on the refrigerator, shut off the gas supply. Disconnect the gas supply line at the rear of the refrigerator. Always use a back up wrench when loosening and tightening this connection. Cap the gas supply line and remove the refrigerator. Replacement is the reverse of removal. Check all connections for gas leaks.

Refer to Chapter 2 INSTALLATION

PERIODIC MAINTENANCE

Before working on refrigerator, shut off the gas supply. Disconnect the gas line at the rear of the refrigerator. Always use a back up wrench when loosening and tightening this connection. Cap the gas supply line and remove refrigerator. Replacement is the reverse of removal. Check all connections for gas leaks. Refer to Chapter 2, Installation.

To keep your refrigerator operating effectively and safely, periodic inspection and cleaning of several components is recommended once or twice a year, sometimes more often depending on environment.

- It's important to keep the area at the back of the refrigerator clean. Clean the coils on the back of the refrigerator. Use a soft bristled brush to dust off the coils.



Note: The following maintenance is required at least once or twice a year.



- Check all connectors in the complete refrigerator LP gas system for gas leaks. The LP gas supply must be turned on. Apply a non corrosive bubble solution to all LP connections. The appearance of bubbles indicates a leak and should be repaired **immediately** by a qualified serviceman.



WARNING – DO NOT USE FLAME TO CHECK FOR GAS LEAKS

Check burner flame for proper appearance. The flame should be light blue with no yellow at the tip. See figure #6

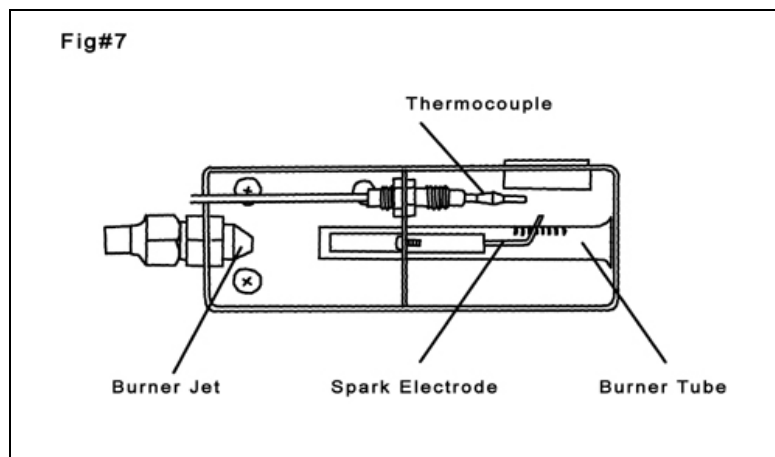
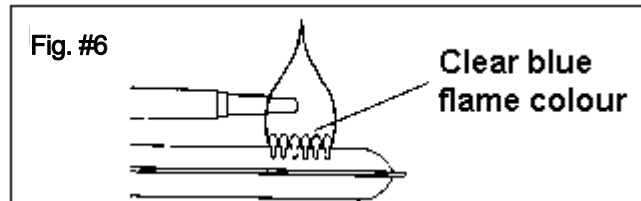

- The LP gas pressure should be checked and the main regulator readjusted if pressure is incorrect. The correct operating pressure is 11" W.C. (water column).
- Inspect the flue baffle, it should be clean and free of soot. Any soot formation indicates improper functioning of the burner. The flue and burner both require cleaning in the following manner:
 - Remove cover from the burner housing.
 - Disconnect the wire from the spark electrode
 - Remove the burner
 - Remove the wire and flue baffle from the top of flue tube. Clean the flue from the top using a flue brush, **be sure to cover the burner if remaining intact** to eliminate dirt falling into burner. Replace the flue baffle.
 - Clean burner tube with compressed air, check for fluff or spider webs.

- Before removing burner orifice, clean burner area of any soot, scale or dirt . Remove the orifice and soak it in alcohol (isopropyl alcohol or thinners) and blow it out with compressed air. Re-install and tighten burner orifice.
- Re-install burner

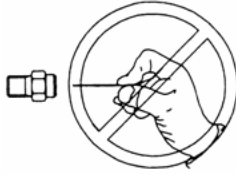

Warning - DO NOT use a pin or wire when cleaning the burner orifice as damage can occur to the precision opening. This can cause damage to the refrigerator or create a fire hazard. It will also create extremely dangerous levels of carbon monoxide.

- Be sure to reconnect the wire to the electrode. Check the electrode for proper location and gap. See figure #8

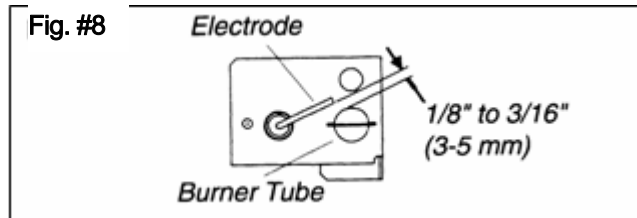

- The inlet & outlet gas fittings on the refrigerator need to be checked for leaks. Apply a non corrosive bubble solution to the fittings and observe for leaks. The safety valve will not allow gas pressure to any connections between it and the burner orifice. These fittings must be checked while burner is in operation (gas flow will be present between safety valve and burner head)



WARNING – The safety valve (“E” button Fig#5) must be manually depressed to allow gas pressure to flow to the burner orifice. Be sure to apply the leak check solution before depressing the safety shut–off. **DO NOT** allow any open flame, sparks, smoking, etc. in the area of the test. **DO NOT** depress safety shut-off for over 30 seconds.



- If leak occurs, then allow ten minutes to dissipate from the burner area. Fix leak then light the burner according to the instructions under GENERAL OPERATIONG INSTRUCTIONS – GAS OPERATION, CHAPTER 3

TROUBLESHOOTING INSTRUCTIONS & SUGGESTED SPARE PARTS TO KEEP ON HAND

REFRIGERATOR DOES NOT COOL, CHECK LIKELY CAUSES:

1. Burner orifice clogged. Clean. See section Maintenance & Service, CHAPTER 4, Item #2. Periodic Maintenance, Items 1-9.
2. Check to ensure refrigerator is level – (left to right and front to back).
3. Restriction on air flow across cooling unit.
4. Heavy frost build up on evaporator fins. Defrost.
5. Flue baffle not inserted properly in flue tube.
6. Improperly set thermostat. See paragraph on thermostat. In hot weather or heavy use the setting should be closer to “Max” than usual.
7. Burner dirty. Clean. See Section MAINTENANCE & SERVICE, CHAPTER 4, PERIODIC MAINTENANCE
8. LP gas pressure low at burner. Regulator pressure must not drop below 11 inches W.C (water column). CHAPTER 2, GAS CONNECTION
9. Burner not located properly under the flue tube. Relocate, flame must be directly into flue
10. Burner damaged. Replace.
11. Odours and fumes
 - Dislocated burner
 - Damaged Burner
 - Dirty orifice
 - Dirty flue tube – CHAPTER 4.

Spare Parts

The following is a list of commonly used parts which are available:

- Burner orifice
- Burner
- Electrode
- Thermocouple
- Safety valve & Thermostat
- Piezo Igniter (push button)
- Baffle

Contact your dealer or an authorized service center for parts and repairs as needed. Quote Model & Serial # - See CSA rating/serial plate on inside left wall.

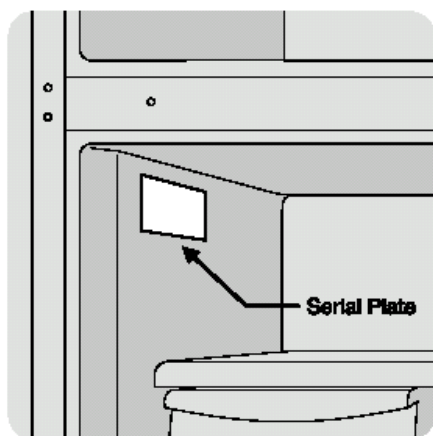

Carbon Monoxide Monitor Instructions for
UGP-15 CM

Model

UNIQUE

OWNER'S MANUAL

Model 9RV-SSO

Carbon Monoxide Alarm for Appliance Safety Shutoff
ATTENTION: PLEASE READ, FOLLOW AND SAVE!

(See Additional Instruction Sheet for Safety Shutoff Connection)

Dear New COSTAR 9RV-SSO Owner,

Congratulations as you have taken steps to help insure the health and life safety of you and your family. We are proud to offer you our unique, patented CO Sensor technology that detects CO in a manner similar to the human body's response.

*Please read this owner's manual carefully so you will have a better understanding of the effects of CO poisoning and the **COSTAR** 9RV-SSO Alarm in conjunction with our **UNIQUE** propane refrigerator.*

To your good health and safety,

Unique Gas Products



WARNING: *Failure to replace this product by the "REPLACE BY DATE" printed on the alarm cover may result in death by Carbon Monoxide poisoning. Replace by date is six (6) years from date of manufacture.*

1.0 WHAT YOU SHOULD KNOW ABOUT CO

Carbon monoxide (CO) is an insidious poison. It is a colorless, odorless and tasteless gas. It is a cumulative poison. The following symptoms are related to CARBON MONOXIDE POISONING and should be discussed with ALL members of the household:

MILD EXPOSURE

Slight headache, nausea, vomiting, fatigue (often described as "flu-like" symptoms)

MEDIUM EXPOSURE

Severe throbbing headache, drowsiness, confusion, fast heart rate

EXTREME EXPOSURE

Unconsciousness, convulsions, cardio respiratory failure, death

Many cases of reported CARBON MONOXIDE POISONING indicate that while victims are aware they are not well, they become so disoriented they are unable to save themselves by either exiting the building or calling for assistance. Also, young children and household pets may be the first affected.

Your CO alarm is designed to detect the toxic CO fumes that result from incomplete combustion, such as those emitted from appliances, furnaces, fireplaces and auto exhaust. A CO Alarm is NOT A SUBSTITUTE for other combustible gas, fire or smoke alarms. This carbon monoxide alarm is designed to detect carbon monoxide gas from ANY source of combustion.

CAUTION: This alarm will only indicate the presence of carbon monoxide gas at the sensor. Carbon monoxide gas may be present in other areas.

CAUTION: This product is intended for use in ordinary indoor locations of family living units. It is not designed to comply with Occupational Safety and Health Administration (OSHA) commercial or industrial standards. Individuals with medical problems may consider using warning devices that provide audible and visual signals for carbon monoxide concentrations under 30 ppm. .

2.0 WHAT YOU SHOULD DO IF THE ALARM SOUNDS

 **WARNING:** Activation of this device indicates the presence of carbon monoxide (CO) which can KILL YOU. If alarm sounds:

For Users in the United States, follow the protocol in steps 1 through 4 below:

- 1 Operate reset/silence button;
- 2 Call your emergency services (____ - _____) [fire department or 911];
- 3 Immediately move to fresh air – outdoors or by an open door/window. Do a head count to check that all persons are accounted for. Do not reenter the premises nor move away from the open door/window until the emergency services responders have arrived, the premises have been aired out, and your alarm remains in its normal condition.
- 4 After following steps 1-3, if your alarm reactivates within a 24 hour period, repeat steps 1-3 and call a qualified technician (____ - _____) to investigate for sources of CO from fuel burning equipment and appliances, motor vehicles or other sources and inspect for proper operation of this equipment. If problems are identified during this inspection, have the equipment serviced immediately. Note any combustion equipment not inspected by the technician and consult the manufacturers' instructions or contact the manufacturers directly for more information about CO safety and this equipment. Make sure that motor vehicles are not and have not been operating in an attached garage or adjacent to the residence.

For users in Canada, follow the protocol in steps 1 and 2 below:

1. Immediately move to fresh air – outdoors or by an open door or window. Check that all persons are accounted for. Do not re-enter the premises or move away from the open door/window until the emergency services responders have arrived; the premises have been aired out, and your alarm remains in its normal condition;
2. Call your emergency services (____ - _____) [fire department or 911]; If “service” signal sounds (RED LED flashes and horn beeps every 30 seconds); contact your retailer the manufacturer for troubleshooting and/or instructions to return the unit:

2.1 IMPORTANT CONSIDERATIONS:

The **COSTAR 9R17-SSO** has been designed and is warranted to operate for six years. Never disconnect the battery to silence an alarm. The alarm will automatically sense when the level of CO in the air falls below the danger level. You should stay outside the residence, or unconditioned area and remain in fresh air until the alarm is silenced. When the alarm sounds, do not stand too close to the alarm. The sound produced by the alarm is loud because it is designed to awaken a person in an emergency. Prolonged exposure to the alarm at a close distance may be harmful to your hearing.

3.0 DEVELOPING YOUR OWN CO SAFETY PLAN

This CO alarm can quickly alert you to the presence of CO — it cannot prevent toxic CO emissions. Please note that there are hazards against which CO detection may not be effective, such as gas leaks or explosions. The ultimate responsibility for protection against toxic CO fumes rests solely on you. Installing CO detectors is just the first step in protecting your family from toxic CO poisoning. We also suggest that you create an effective, comprehensive safety program as outlined below.

- 3.1 Install CO detectors properly following the instructions in this manual.
- 3.2 Develop a family escape plan and practice it with your entire family, especially small children.
 - Draw a floor plan of your home and find two ways to exit from each room. There should be one way to get out of each bedroom without opening the door.
 - Make sure that all occupants know what the CO alarm signal means and how they must exit the residence by themselves if necessary.
 - Decide on a meeting place a safe distance from your house and make sure all occupants understand where they should go and wait if there is a dangerous CO condition.
 - Conduct CO safety drills at least every 6 months to make sure that everyone, even small children, know what to do in order to escape safely.
 - Know where to go to call the Fire Department or professional assistance from outside your residence.
 - Know where to go call the emergency service provider and or a qualified service technician.

4.0 IMPORTANT: WHAT YOUR CO ALARM CAN AND CANNOT DO

- 4.1 This unit is designed to detect carbon monoxide (CO) and shutoff an appliance for safety only.

- 4.2 This CO alarm is designed for use within a single residential living unit. It is designed to detect carbon monoxide (CO) entering its sensing chamber. It does not sense combustible gas (such as natural gas, propane or (butane), heat, smoke or flames
- 4.3 This CO alarm may not provide early warning for occupants if it is placed outside of the house, such as on outside porches.
- 4.4 When properly located, installed, and maintained, this CO alarm is designed to provide early warning of developing poisonous CO conditions at a reasonable cost. This alarm monitors the air, and when it senses CO, it activates its built-in alarm. It can provide precious time for you and your family to escape from your residence before CO can seriously injure or kill. However, such an early warning is possible only if the alarm is located, installed, and maintained as specified in the Owner's Manual and the Instruction for the Safety Shutoff Connection.

5.0 INSTALLING THE COSTAR 9RV-SSO

- 5.1 One of the most important considerations in any CO alarm system is the location of the alarms. Statistics of the National Fire Protection Association (NFPA) show that most of the fatal CO occurrences happen at night while people are sleeping and/or while they are in the garage. Early warning of CO is best achieved by the correct installation of CO alarms.
- 5.2 This CO alarm may be mounted on the wall.

WALL LOCATION:
 Mount the alarm at least 3 feet (usually 5 – 6 feet) from the floor.

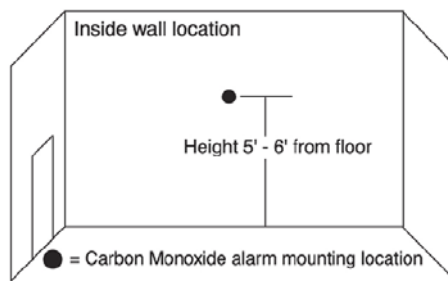

Figure 1: Recommended CO alarm wall mounting location is 5 to 6 feet from floor

- 5.3 **LOCATIONS TO AVOID:** Nuisance alarms are caused by placing units where they will not operate properly. To avoid nuisance alarms, do not place units:
 - Within 5 feet (1.5m) of any cooking appliance or furnace.
 - Near an open window or door, because the fresh air entering the opening may

delay CO from reaching the alarm.

- In damp or very humid areas or next to bathrooms with showers. Install detectors at least 10 feet (3 meters) away from bathrooms.

- In very cold or very hot environments or in unheated buildings or outdoor rooms where the temperature can go below or above the operating range of the alarm. Temperature limits for proper operation are -20° F to 120° F (-29° C to 49° C); Operating Humidity is 10 – 95% RH.

- Good ventilation is recommended when household cleaning supplies or similar contaminants are used.

5.4 **CONDITIONS WHICH CAN RESULT IN TEMPORARY CO SITUATIONS:**

5.4.1 Excessive spillage or reverse venting of fuel burning appliances (woodstoves, etc) caused by outdoor ambient conditions, such as:

- 1 Wind direction and/or velocity, including high gusts of wind. Heavy air in the vent pipes (cold/humid air with extended periods between cycles).
- 2 Negative pressure differential resulting from the use of exhaust fans, lack of combustion air entering building or dwelling.
- 3 Simultaneous operation of several fuel burning appliances competing for limited internal air.
- 4 Vent pipe connections vibrating loose from clothes dryers, furnaces, refrigerators, or water heaters.
- 5 Obstructions in or unconventional vent pipe designs which can amplify the above situations.

5.4.2 Extended operation of un-vented fuel burning devices (range, oven, fireplace, etc.)

5.4.3 Temperature inversions, which can trap, exhaust gasses near the ground.

5.4.4 Car or generator idling in an open or closed area garage, or near a home.

6.0 **INSTALLATION INSTRUCTIONS: READ CAREFULLY BEFORE INSTALLING ALARM**

CAUTION: THIS UNIT IS SEALED. THE COVER IS NOT REMOVABLE!

6.1 Select proper location (See section 5.0)

6.2 A mounting plate is provided on the back of the alarm. Remove the mounting plate from the back of the alarm by holding the mounting plate and twisting the alarm in the direction indicated by the "OFF" arrow on the alarm cover.

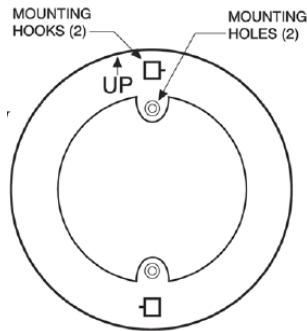

Step A: Wall Alignment

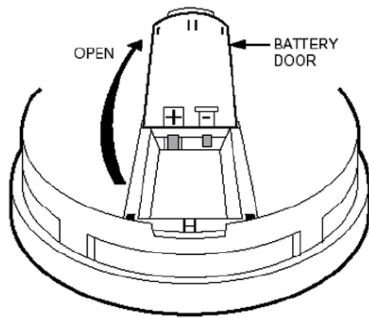

Step B: Alarm Activation

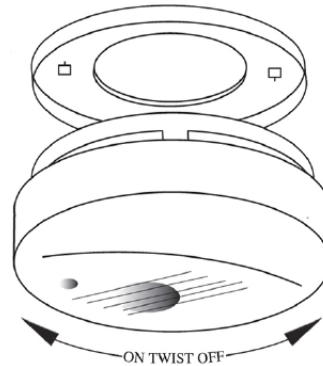

Step C: Removal and Installation

Figure 2: Installation Instructions

6.3 To insure aesthetic alignment of the alarm with the hallway or wall, the UP ↑ arrow on the mounting plate must be vertical when wall mounting:

(See Step A above in Figure 2)

6.4 As described in Figure 2, attach the mounting plate on the wall. Use the screws and anchors provided to secure the mounting plate.

6.5 The battery is **INSTALLED REVERSED FOR SHIPPING**. Remove and reinstall the battery in the correct orientation as noted on the inside of the battery door. When installing the battery, align the “+” and “-” battery terminals on the correct contacts. The alarm will beep once indicating proper battery installation.

WARNING: Battery is required for operation of appliance, alarm operation and detection of carbon monoxide. If no battery is installed, the appliance will not stay lit.

The battery door will not close easily and the unit will not attach to the mounting bracket.

- 6.6 Twist the alarm in the direction indicated by the “ON” arrow on the alarm cover (see step D) until it locks in place.
- 6.7 To make your carbon monoxide alarm tamper resistant, a locking pin has been provided in the bag with the screws and anchors. Using this pin will deter children and others from removing the alarm from the mounting plate. To use the pin insert it into the hole in the side of the alarm after the alarm has been installed on the mounting plate (See Figure 3). Note the tamper resist pin will have to be removed in order to change the battery; this can be done easily with a long nose pliers. Using the long nose pliers pull the pin out of the hole, it is now possible to remove the alarm from the mounting plate.

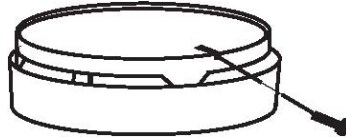

Figure 3: *Tamper Resistant Locking Pin*

- 6.8 *This box contains two self-adhesive labels. You should write the telephone numbers of the emergency service provider and a qualified technician in the space provided on the labels. Place one label next to the alarm, and the other label near a source of fresh air where you plan to gather after the alarm indicates the presence of carbon monoxide.*

7.0 ALARM SIGNALS

- 7.1 **NORMAL OPERATION:** RED L.E.D. flashes once every 30 seconds, indicating that the alarm is powered
- 7.2 **ALARM CONDITION:** Repeating signal pattern: RED LED turns "on" for 2 seconds with 4 short beeps and then 5 seconds of silence. Pushing and holding the test/reset button for 3 seconds will silence the alarm for about 4 minutes. After 4 minutes, the alarm will once again sound until the unsafe CO concentration is reduced.
- 7.3 **TROUBLE/SERVICE CONDITION:** The alarm self-tests every 10 minutes. The alarm will beep and the RED LED flashes once every 30 seconds if a fault is detected. This is an indication of a malfunction and that the detector requires immediate servicing or replaced
- 7.4 **LOW BATTERY:** RED LED flashes and horn chirp every 30 seconds. Replace battery when this signal occurs

8.0 MAINTENANCE CLEANING YOUR ALARM:

- 8.1. Keep your CO alarms clean – use a damp (water only) cloth or vacuum.
- 8.2. To clean your alarm, remove it from the mounting bracket as outlined in Figure 2 Step D: Installation/Removal. IF TAMPER RESISTANT PIN HAS BEEN USED, REFER TO STEP 6.7 UNDER INSTALLATION INSTRUCTIONS FOR REMOVAL INSTRUCTIONS. (See Figure 3)
- 8.3. You can clean the interior of your alarm by using your vacuum cleaner hose and vacuuming through the openings around the perimeter of the alarm.
- 8.4. The outside can be wiped with a cloth.
- 8.5. After cleaning, reinstall your alarm and test your alarm by using the TEST button.
- 8.6. Test your detectors weekly and repair or replace them when they no longer function. As with any electronic product, alarms have a limited life and alarms that do not work cannot protect you. (See section 10.0)

WARNING: Do not use any household cleaning agents, paints, varnishes or any other chemical on your **COSTAR 9RV-SSO** alarm.

9.0 BATTERY REPLACEMENT:

NOTE: IF TAMPER RESISTANT PIN HAS BEEN USED, REFER TO STEP 6.7 UNDER INSTALLATION INSTRUCTIONS FOR REMOVAL INSTRUCTIONS. (See Figure 3)

- 9.1. To replace the battery remove the alarm from the mounting plate by rotating the alarm in the direction of the "OFF" arrow on the cover (See Figure 2 Step D). Remove and reinstall the battery in the correct orientation as noted on the inside of the battery door. The alarm will beep once indicating proper battery installation. After re-installing the battery, place the alarm on the mounting plate. Twist the alarm in the direction indicated by the "ON" arrow on the alarm cover (see Figure 2 step D) until it locks in place.
- 9.2. The **COSTAR 9RV-SSO** CO Alarm uses one (1) 9 volt Alkaline battery. A fresh battery should last for one year under normal operating conditions. They can be purchased anywhere batteries are sold, such as your local hardware store.

9.3 USE ONLY THE FOLLOWING 9 VOLT BATTERY FOR CO ALARM REPLACEMENT:

Alkaline type: DURACELL: MN1604

WARNING USE ONLY THE BATTERY SPECIFIED. USE OF DIFFERENT BATTERIES MAY HAVE A DETRIMENTAL EFFECT ON THE CO ALARM. THE CONSTANT EXPOSURES TO HIGH OR LOW TEMPERATURES OR HIGH HUMIDITY MAY REDUCE BATTERY LIFE. CHECK THE BATTERY MANUFACTURERS SPECIFICATIONS FOR PROPER OPERATING CONDITIONS.

Note: Most batteries are not rated below -20°C or above 54°C

10.0 PERIODIC ALARM TESTING:

Test the alarm for proper operation by pushing the test button until a short beep is heard (approximately three seconds). Release the button. The alarm will then test itself for proper operation and the RED L.E.D. light will flash 4 - 6 times. At completion of the self test, the alarm will sound 2 patterns. The alarm then resumes normal operation.

WARNING: THIS TEST PROCEDURE **WILL TURN OFF** THE APPLIANCE ONCE THE ALARM RESUMES NORMAL OPERATION, RE-LIGHT APPLIANCE FOLLOWING LIGHTING INSTRUCTIONS.

WARNING: RESIDENTIAL USE: TEST ALARM OPERATION AT LEAST ONCE PER WEEK DURING USE OR IF APPLIANCE WAS TURNED OFF FOR A PERIOD OF TIME.

11.0 SERVICE AND WARRANTY

If after reviewing this manual you feel that your CO Alarm is defective in any way, do not tamper with the unit. Call your retailer where you purchased, and they will handle the claim through **UNIQUE..**

Door Removal & Reversal Instructions

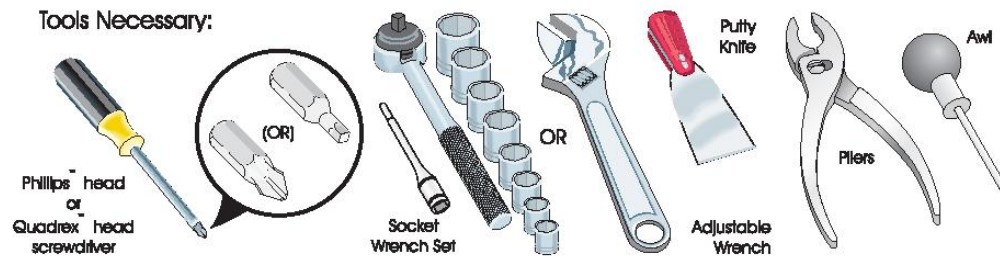

NOTE: The direction in which your refrigerator doors open (door swing) can be reversed, from left to right or right to left, by moving the door hinges from one side to the other. A qualified person should perform reversing the door swing.

1. Remove toe grille and top hinge cover.
2. Remove top hinge with 3/8" hex driver and lift freezer door off of center hinge pin. Set door aside.
3. Unscrew center hinge pin using adjustable wrench and save for reassembly. Ensure plastic washer stays on hinge pin.
4. Lift refrigerator door off of bottom hinge and set aside.
5. Remove center hinge and shim by removing inside screw and loosening two outside screws enough to allow hinge and shim to slide out. Tighten screws. Loosen two outside screws on opposite side of refrigerator, remove inside screw and install center hinge.
6. Remove bottom hinge with 3/8" hex driver. Reinsert two outside screws in holes and tighten. Inside screw will go to opposite side in step 7.
7. Remove two outside screws on opposite side of refrigerator and install bottom hinge. Insert and tighten screws saved from step 6.
8. Unscrew bottom hinge pin using adjustable wrench. Move hinge pin to other hole in hinge and tighten with adjustable wrench.

9. Reverse door handles (see instructions on next page).
10. Move freezer and refrigerator doorstops to opposite side. Before starting screws, use an awl to puncture the foam.
11. Position refrigerator door onto bottom hinge pin and screw center hinge pin through center hinge into top of door. Close refrigerator door to help align hinge hole.
12. Tighten center hinge pin with adjustable wrench.
13. Remove cabinet and hinge hole plugs and move to opposite side.
14. Lower freezer door onto center hinge pin.
15. Close freezer door. Have an assistant lift up on opposite side of door while tightening screws to install top hinge.
16. Replace toe grille and top hinge cover.

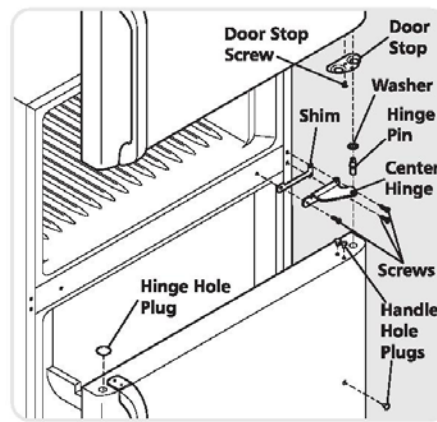
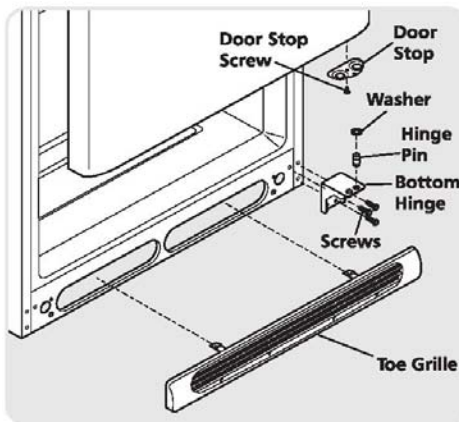
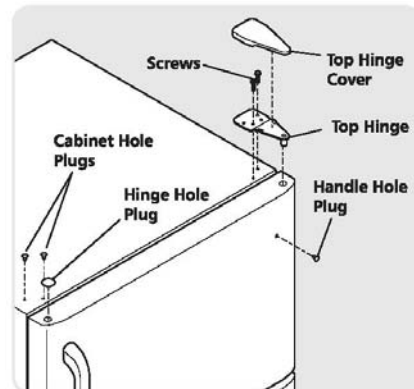
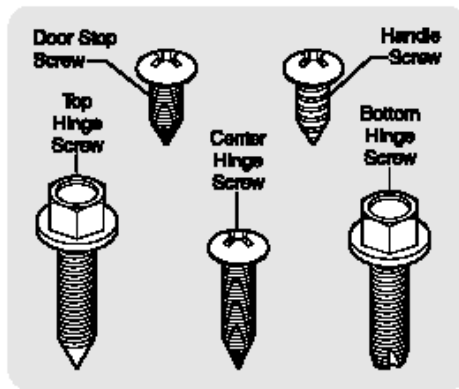

To Remove Freezer Handle

(Handles may be easier to reverse while doors are off.)

1. Remove two screws attaching handle to bottom of freezer door.
2. Remove short trim piece by sliding trim straight up and off handle bracket.
3. Remove screw, attaching top of handle to door.

To Attach Freezer Handle

1. Reinstall handle on opposite side, using same hole as nameplate.
2. Attach handle to bottom of door.

To Remove Refrigerator Handle:

(Handles may be easier to reverse while doors are off.)

1. Remove two screws attaching handle to top of refrigerator door.
2. Remove screw-attaching bottom of handle to door.
3. Remove two hole plugs and hinge pin plug on top of door and install on opposite side. Use slotted screwdriver to remove plastic screw plug from front of door and install on opposite side

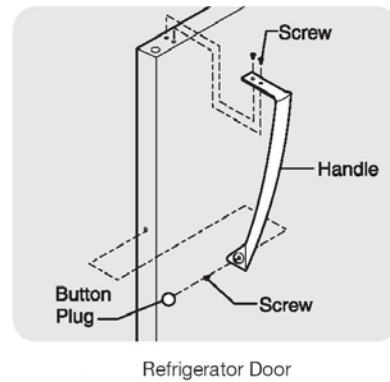

To Attached Refrigerator Handle:

1. Secure bottom of handle with screws.
2. Secure top of handle with screws.



Temperature Controls

Note: Maximum setting is override; therefore the thermostat function is not operational at this setting. This setting is usually only required during very hot and humid days.

COOL DOWN PERIOD

To ensure safe food storage, allow the refrigerator to operate with the doors closed for at least 8 hours before loading it with food.

REFRIGERATOR CONTROL

NOTE: When first setting the controls or when changing a setting, wait 24 hours for the temperature to stabilize before making additional changes.

TEMPERATURE ADJUSTMENT

- **Adjust temperature gradually: move the knob in small increments, allowing the temperature to stabilize.**
- For colder interior temperatures, turn the knob clockwise.
- For a warmer interior temperatures, turn the knob towards counter-clockwise

Adjusting the refrigerator control will change temperatures in both compartments.

Remember there is no fan to circulate the air in the refrigerator and freezer compartments as in an electric fridge. For good circulation, do not block the internal cooling fins on back-wall and try to maintain a temperature of 38° F or 4°C in the fridge

NOTE: When first turning refrigerator on, move refrigerator controls to maximum, which is the recommended initial setting. After 24 hours, adjust the controls as needed.

Looking Inside



SHELF ADJUSTMENT

Refrigerator shelves are easily adjusted to suit individual needs. Before adjusting the shelves, remove all food.

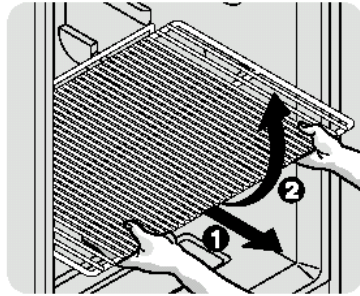

Sliding Wire Shelf

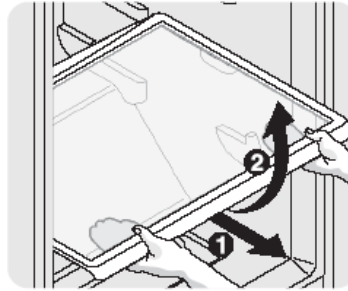

Sliding Glass Shelf

Crispers & Deli Drawers

The crispers, located under the bottom refrigerator shelf, are designed for storing fruits, vegetables, and other fresh produce. Wash items in clear water and remove excess water before placing them in the crispers. Items with strong odors or high moisture content should be wrapped before storing.

Some models are equipped with a Deli Drawer for storage of luncheon meats, spreads, cheeses, and other deli items.

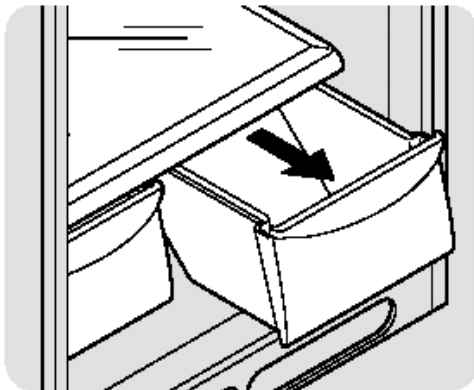

Crisper Drawer

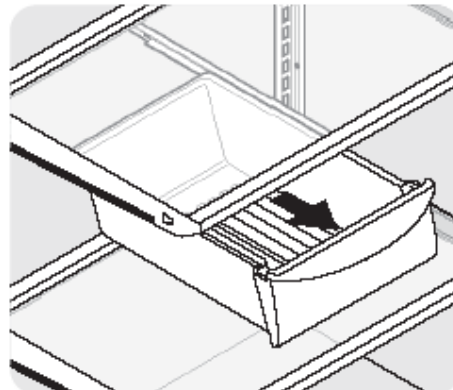

Deli Drawer

Food Storage Ideas

FRESH FOOD STORAGE

- The fresh food compartment should be kept between 38° F and 40° F (3.3° C and 4.4° C) with an optimum temperature of 38° F (3.3°C).
- Avoid overcrowding the refrigerator shelves. This reduces the circulation of air around the food and results in uneven cooling.

FRUITS AND VEGETABLES

- Storage in the crisper drawers traps moisture to help preserve the fruit and vegetable quality for longer time periods.

MEAT

- Raw meat and poultry should be wrapped securely so leakage and contamination of other foods or surfaces does not occur.

FROZEN FOOD STORAGE

- The freezer compartment should be kept at 8.6°F (-13°C) at a 77°F (25°C) room ambient
- A freezer operates most efficiently when it is slowly loaded to 2/3 full.

PACKAGING FOODS FOR FREEZING

- To minimize dehydration and quality deterioration, use aluminum foil, freezer wrap, freezer bags or airtight containers.
- Force as much air out of the packages as possible and seal them tightly. Trapped air can cause food to dry out, change color, and develop an off-flavor (freezer burn).
- Wrap fresh meats and poultry with suitable freezer wrap prior to freezing.
- Do not refreeze meat that has completely thawed.

LOADING THE FREEZER

- Avoid adding too much warm food to the freezer at one time. This overloads the freezer, slows the rate of freezing, and can raise the temperature of frozen foods.
- Leave a space between the packages, so cold air can circulate freely, allowing food to freeze as quickly as possible.

Care and Cleaning

Keep your refrigerator and freezer clean to prevent odor build-up. Wipe up any spills immediately and clean both sections at least twice a year. **Never** use metallic scouring pads, brushes, abrasive cleaners or strong alkaline solutions on any surface. **Do not** wash any removable parts in a dishwasher.

- **When moving the refrigerator, pull straight out. You must turn gas off at source or have adequate flex line to move refrigerator. Do not shift the refrigerator from side to side as this may tear or gouge the floor covering and damage the gas supply line.**
- **Damp objects stick to cold metal surfaces. Do not touch refrigerated surfaces with wet or damp hands.**

NOTES:

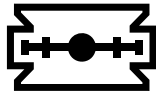

Do not use razor blades or other sharp instruments, which can scratch the appliance surface when removing adhesive labels. Any glue left from tape or labels can be removed with a mixture of warm water and mild detergent, or, touch the glue residue with the sticky side of tape you have already removed. **Do not remove the certification/serial plate, lighting instructions or CO warning label.**

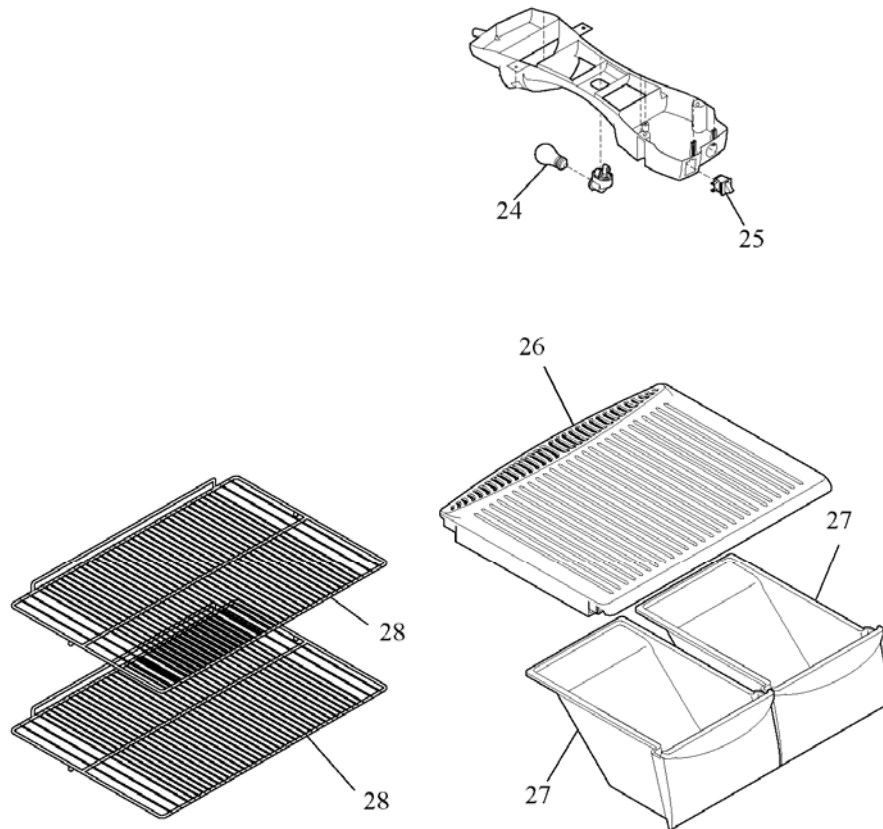

CO-Monitor and Components

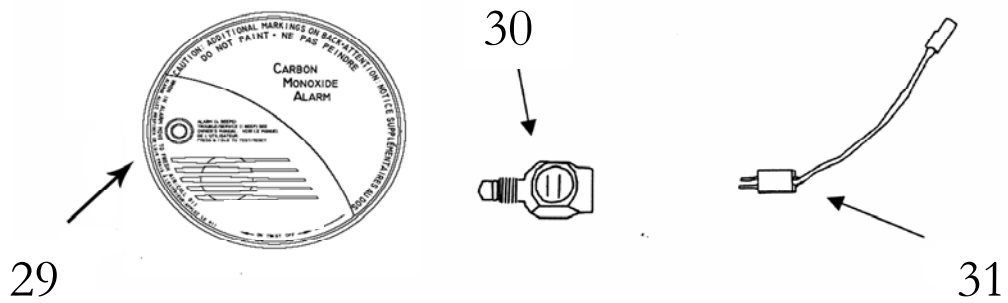

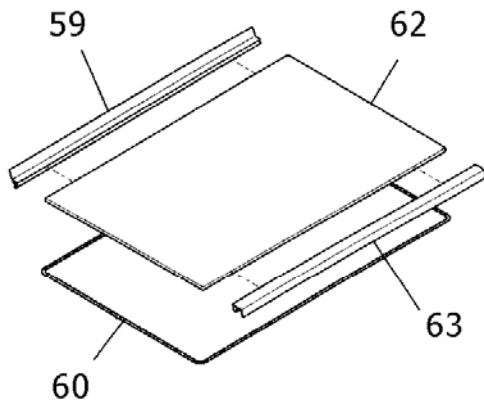

Stainless and Glass Fridge Interior

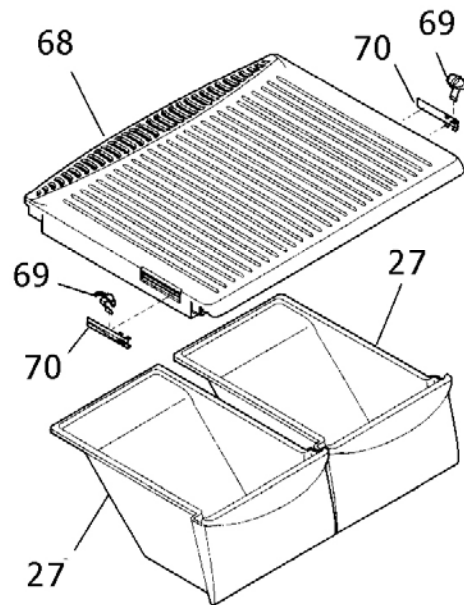
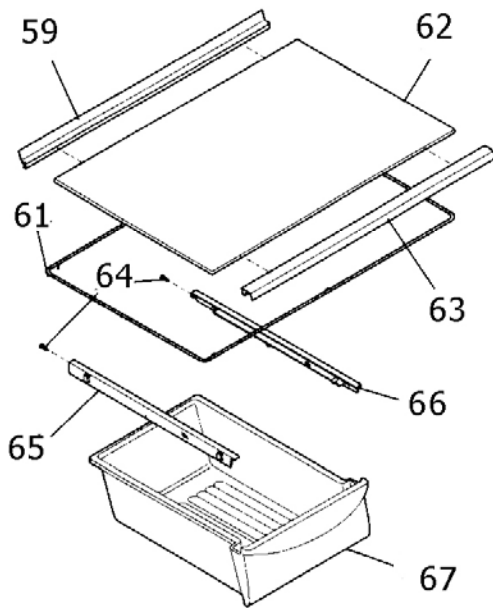

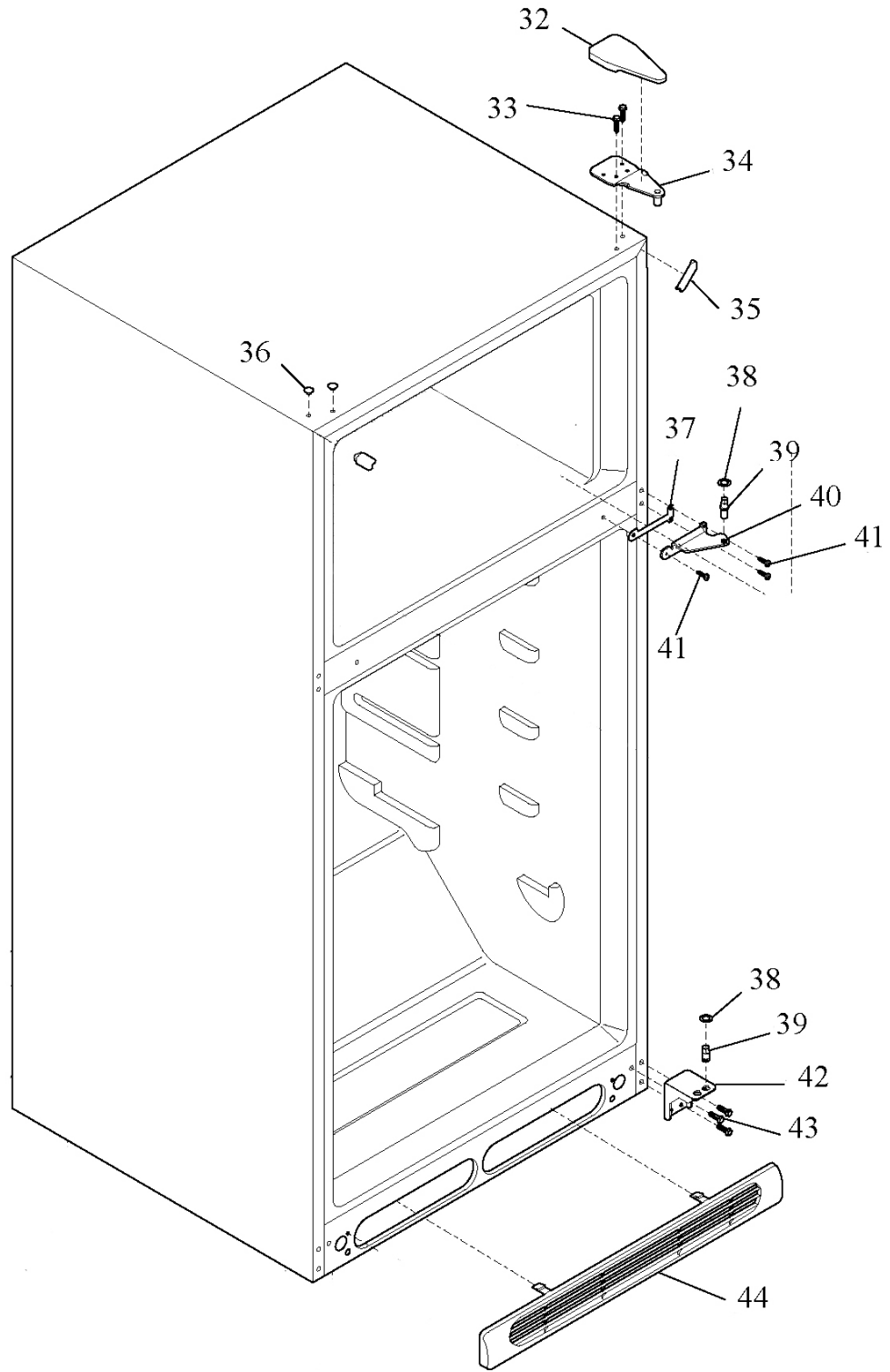

Burner Train Assembly

UGP15

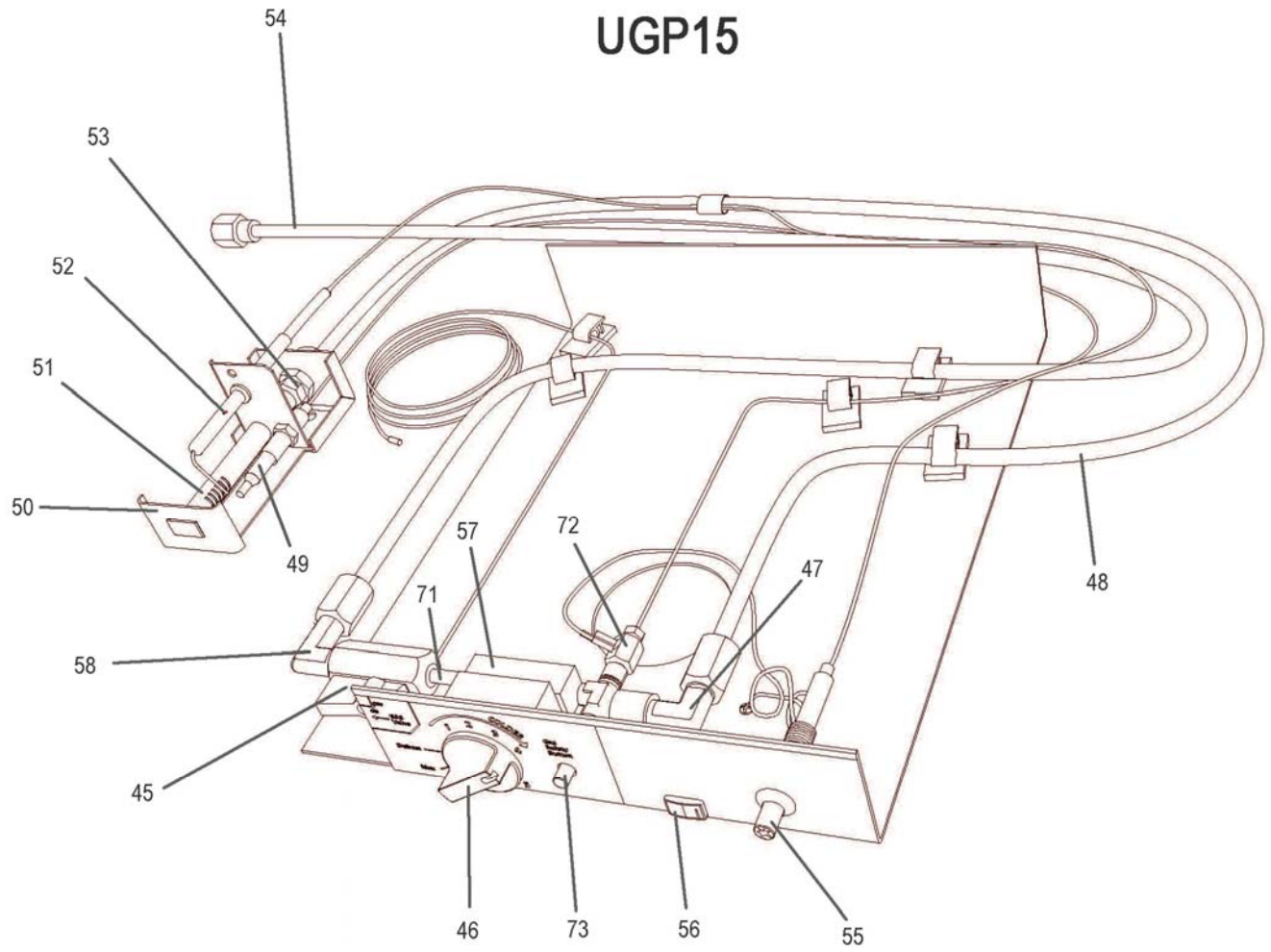

UNIQUE UGP-15 Fridge (15 cu/ft)		
Item#	PART#	DESCRIPTION
1	UGP15-01	FREEZER DOOR GASKET
	UGP15-01-1	FREEZER DOOR GASKET – BLACK FOR STAINLESS STEEL FRIDGE ONLY
2	UGP15-02	PLUG
3	UGP15-03	FREEZER DOOR- WHITE
	UGP15-03-1	FREEZER DOOR- STAINLESS STEEL (MUST REQUEST LEFT OR RIGHT HANDED OPENING)
4	UGP15-04	CAP
5	UGP15-05	HANDLE - SCREW
6	UGP15-06	HANDLE - BLOCK
6a	UGP15-06-1	CAP – HANDLE BLACK FOR STAINLESS STEEL FRIDGE ONLY
7	UGP15-07	HANDLE - BUTTON
8	UGP15-08	HANDLE - SCREW
9	UGP15-09	PLUG
10	UGP15-10	DOOR HANDLE - FRIDGE AND FREEZER - WHITE
10a	UGP15-10-1	DOOR HANDLE - FRIDGE AND FREEZER – BLACK FOR STAINLESS STEEL FRIDGE ONLY
11	UGP15-11	FRIDGE DOOR - WHITE
	UGP15-11-1	FRIDGE DOOR -STAINLESS STEEL FOR STAINLESS STEEL FRIDGE ONLY
12	UGP15-12	SCREW
13	UGP15-13	DOOR STOP – BOTTOM FRIDGE DOOR – WHITE
	UGP15-13-1	DOOR STOP – BOTTOM FRIDGE DOOR – BLACK FOR STAINLESS STEEL FRIDGE ONLY
14	UGP15-14	SUPPORT DOOR RACK – RH
15	UGP15-15	SUPPORT DOOR RACK – LH
16	UGP15-16	DOOR GUARD – 18.65"

Item#	PART#	DESCRIPTION
17	UGP15-17	SUPPORT DOOR - RH
18	UGP15-18	SUPPORT DOOR - LH
19	UGP15-19	DAIRY DOOR
	UGP15-19-1	DAIRY DOOR – CLEAR FOR STAINLESS STEEL FRIDGE ONLY
20	UGP15-20	DOOR GUARD – 16.21"
21	UGP15-21	FRIDGE – DOOR GASKET
	UGP15-21-1	FRIDGE – DOOR GASKET - BLACK FOR STAINLESS STEEL FRIDGE ONLY
22	UGP15-22	DOOR STOP – BOTTOM FREEZER DOOR
	UGP15-22-1	DOOR STOP – BOTTOM FREEZER DOOR - BLACK FOR STAINLESS STEEL FRIDGE ONLY
23	UGP15-23	DOOR GUARD - 9.04"
24	UGP15-24	INTERIOR LIGHT
25	UGP15-25	SWITCH
26	UGP15-26	COVER - CRISPER PAN
27	UGP15-27	CRISPER DRAWERS
28	UGP15-28	WIRE SHELVES
29	UGP- 9RV-SSO	CO DETECTOR 9RV SSO
30	QMP- INTERRUPTER BLOCK	INTERRUPTER BLOCK – ONLY USED ON CO-MONITORED FRIDGES
31	QMP-15-FET	MOSFET ASSY
32	UGP15-32	TOP HINGE COVER
33	UGP15-33	TOP HINGE SCREWS
34	UGP15-34	TOP HINGE
35	UGP15-35	CORNER TRIM

Item#	PART#	DESCRIPTION
36	UGP15-36	PLUG – WHITE
37	UGP15-37	HINGE SPACER
38	UGP15-38	NYLON WASHER
39	UGP15-39	PIN – CENTER HINGE
40	UGP15-40	CENTER HINGE
41	UGP15-41	CENTER HINGE SCREWS
42	UGP15-42	BOTTOM HINGE
43	UGP15-43	BOTTOM HINGE SCREWS
44	UGP15-44	FRONT GRILL
45	UGP1518-1	ON/OFF VALVE
46	UGP1518-2	THERMOSTAT KNOB
47	UGP1518-3	OUTLET FITTING
48	UGP1518-4	OUTLET GAS TUBE
49	UGP15-49	THERMOCOUPLE
50	UGP15-50	BURNER BRACKET
51	UGP15-51	BURNER TUBE
52	UGP15-52	ELECTRODE WITH WIRE
53	UGP15-53	ORIFICE
54	UGP1518-5	INLET GAS TUBE
55	UGP15-55	PEIZO IGNITOR
56	UGP15-56	FLAME INDICATOR
57	UGP1518-6	THERMOSTAT CONTROL

Item#	PART#	DESCRIPTION
58	UGP1518-7	INLET GAS FITTING
59	UGP15-59	TRIM – REAR 16"
60	UGP15-60	FRAME - SHELF
61	UGP15-61	FRAME - SHELF WITH HANGERTABS
62	UGP15-62	GLASS SHELF – NO PATTERN
62	UGP15-62-1	GLASS SHELF – PATTERN ON GLASS STAINLESS STEEL UNIT ONLY
63	UGP15-64	TRIM - FRONT
64	UGP15-65	SCREW – FOR HANGERS STAINLESS STEEL UNIT ONLY
65	UGP15-65-1	TRACK – HANGER LH STAINLESS STEEL UNIT ONLY
66	UGP15-66	TRACK – HANGER RH STAINLESS STEEL UNIT ONLY
67	UGP15-67	MEAT BIN STAINLESS STEEL UNIT ONLY
68	UGP15-68	COVER - CRISPER DRAWERS
69	UGP15-69	CONTROL – HUMIDITY (NOT FUNCTIONAL ON PROPANE FRIDGES)
70	UGP15-70	DAMPER – HUMIDITY CONTROL (NOT FUNCTIONAL ON PROPANE FRIDGES)
71	UGP1518-8	PIPE – ON/OFF VALVE TO THERMOSTAT CONTROL
72	UGPSPBLOCK	SINGLE PRONG INTERRUPTER BLOCK
73	UGP1518-9	SAFETY VALVE



UNIQUE UGP15

5 YEAR LIMITED WARRANTY*

Unique Gas Products Ltd. warrants that this **UNIQUE** refrigerator is free from defects in material and workmanship under normal usage and service under the following terms:

1. This Warranty is made only to the first purchaser ("original purchaser") who acquires this refrigerator for his/her own use and will be honored by **Unique Gas Products Ltd.** and by the Seller.
2. Any part of this refrigerator returned to the Seller or **Unique Gas Products Ltd.**, which upon examination is determined by them to have been defective in material or workmanship, will at their option be either repaired or replaced under this warranty, without charge for materials/parts. (customer is responsible for labour)
3. The obligation to repair or replace defective parts will apply only to parts returned within one year of the date of purchase and will constitute the Sellers sole obligation under this Warranty. The cooling system (coil) is warranted for a total of five years and will be replaced at no charge by **Unique Gas Products Ltd.** and the Seller (labour and transportation charges will be the responsibility of the owner). Coils replaced during the initial five-year period will be warranted only for the remaining portion.

The Seller will have no obligation under this warranty with respect to conditions unrelated to the material or workmanship of this refrigerator. Such unrelated conditions include without limitation:

- a) faulty installation (or venting) and damage resulting therefrom; not installed by Seller
- b) the need for normal maintenance of this refrigerator (including the cleaning of the Burner, Venturi, orifice, flue tubes and assurance of proper propane gas pressure);
- c) any accidents to or misuse of any part of this refrigerator and any alteration thereof by anyone other than the Seller or its authorized representative.

This **UNIQUE** Refrigerator **must** be serviced regularly as outlined in the Owner's Manual. **Unique Gas Products Ltd.** the seller will not be liable for direct or indirect loss of foods caused by failure in operation. In case of damage, the owner must provide proof of purchase, Model, and Serial Number to the Seller or **Unique Gas Products Ltd.**

*Due to remote locations, it is the customer's responsibility to bring items to dealer for review.

Please fill out warranty card within 30 days and mail back for warranty coverage



LIMITED WARRANTY

COSTAR Model 9RV-SSO

UNIQUE GAS PRODUCTS LTD offers you this limited warranty on your new carbon monoxide alarm, including all of its component parts except the battery. This limited warranty extends solely to the original end-user purchaser of this product, provided your purchase was made from an authorized vendor. Transfer or resale of this product will automatically terminate warranty coverage.

UNIQUE GAS PRODUCTS LTD. warrants the enclosed carbon monoxide alarm to be free from defects in materials and workmanship under authorized use and service, as specified in the owner's manual, for a period of six (6) years from the date of manufacture. During the initial two (2) year period commencing with the date of manufacture, any repair or replacement shall be made without charge. During the latter four (4) years of the warranty period, any repair or replacement shall be made at a charge to the purchaser not to exceed the manufacturer's cost of repair or replacement. All replaced items become the property of UNIQUE GAS PRODUCTS LTD..

UNIQUE GAS PRODUCTS LTD.. MAKES NO OTHER WARRANTIES, EXPRESS OR IMPLIED, EXCEPT AS REQUIRED BY LAW, AND IN NO CASE FOR A DURATION LONGER THAN THAT OF THIS WRITTEN WARRANTY, EXCEPT AS REQUIRED BY LAW, INCLUDING, BUT NOT LIMITED TO, ANY WARRANTY OF MERCHANTABILITY OR FITNESS FOR A PARTICULAR PURPOSE OR AGAINST INFRINGEMENT, OR ANY EXPRESS OR IMPLIED WARRANTY ARISING OUT OF TRADE USAGE OR OUT OF A COURSE OF DEALING OR COURSE OF PERFORMANCE. UNIQUE GAS PRODUCTS LTD.. has not authorized any other party to extend any other warranties in connection with the sale of the product, and will not accept responsibility for any statements, representations, or warranties made by any other person.

This limited warranty does not cover: (1) 9 volt alkaline battery; (2) products which have been improperly installed, repaired, maintained, modified, or which have been subjected to misuse, abuse, accident, neglect, exposure to fire, water, or excessive changes in climate or temperature, or combined with non-UNIQUE GAS PRODUCTS LTD.. - approved accessories; (3) physical damage caused from use other than normal and proper operation or handling, as specified in the owner's manual; (4) cosmetic damage; (5) products on which warranty stickers or product serial numbers have been removed, altered, or rendered illegible; (6) the cost of installation, removal or reinstallation.

UNIQUE GAS PRODUCTS LTD. SPECIFICALLY DISCLAIMS LIABILITY FOR ANY AND ALL DIRECT, INDIRECT, SPECIAL, GENERAL, INCIDENTAL, OR CONSEQUENTIAL DAMAGES, INCLUDING, BUT NOT LIMITED TO, LOSS OF PROFITS OR ANTICIPATED PROFITS ARISING OUT OF USE OF OR INABILITY TO USE THE PRODUCT.