UNIQUE®

2245 Wyecroft Road #5, Oakville, Ontario Canada L6L 5L7
Ph: 905-827-6157 Toll Free: 1-877-427-2266 Fax: 905-827-2027
www.UniqueOffGrid.com

Parts Guide - Current

UGP 15
Direct Vent



"Personal Service & Knowledge makes us Unique"

Parts Diagram and List

Interior of Fridge

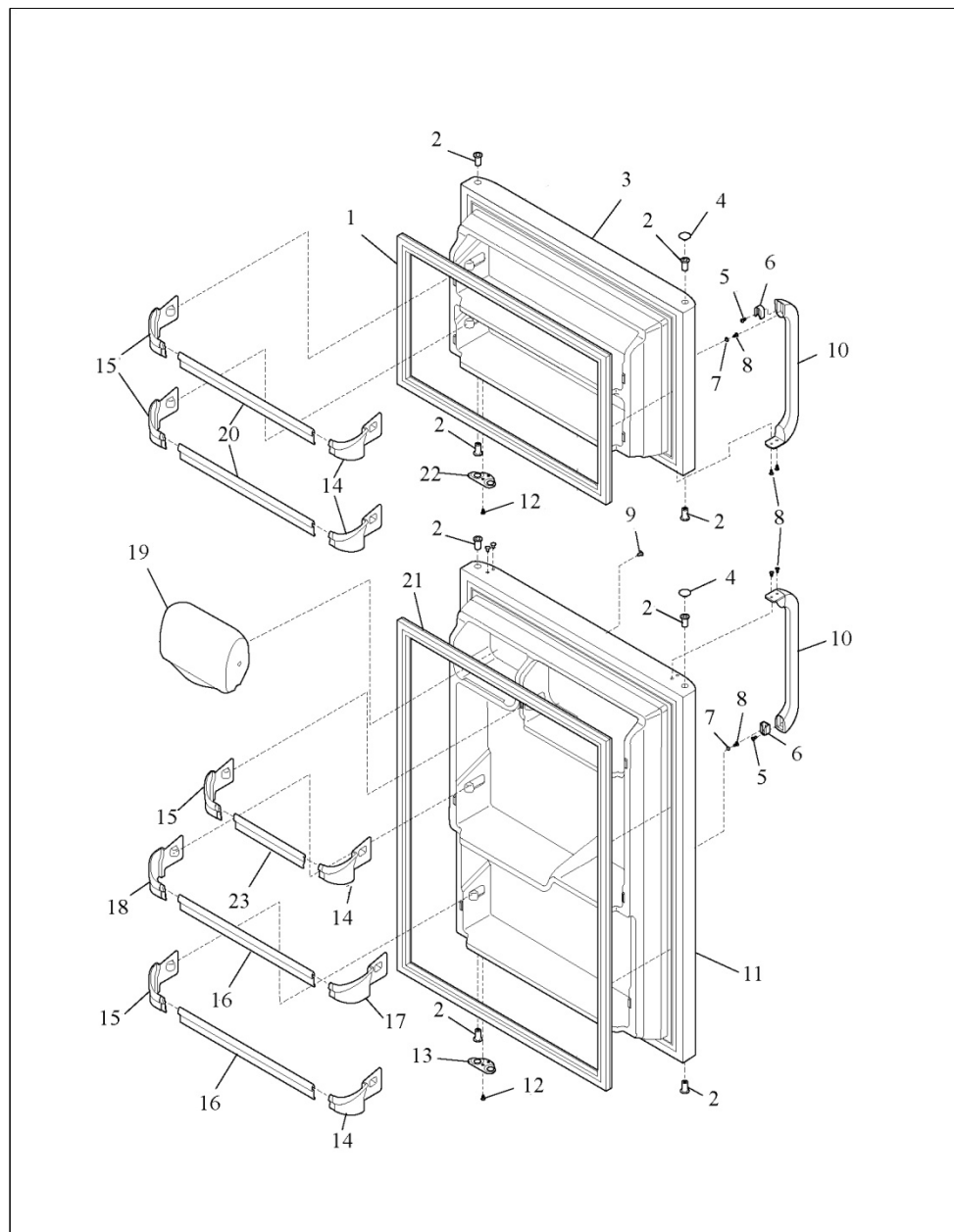

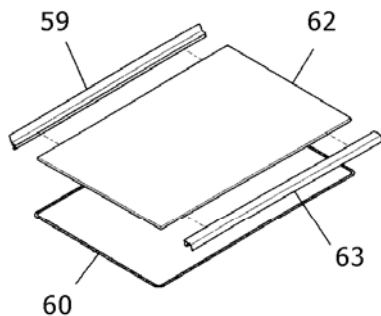
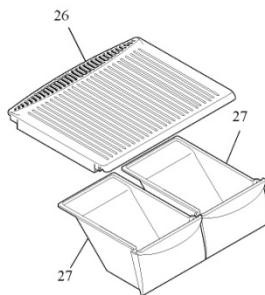
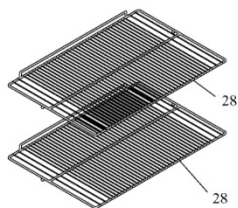
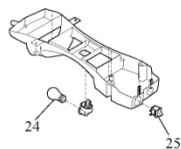

Stainless and Glass Fridge Interior

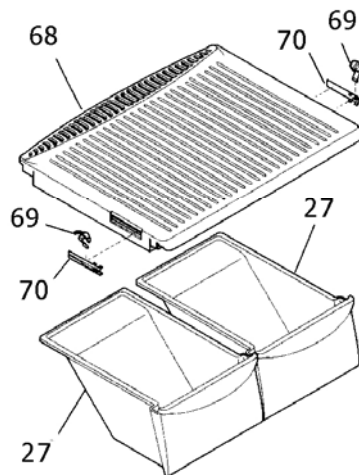
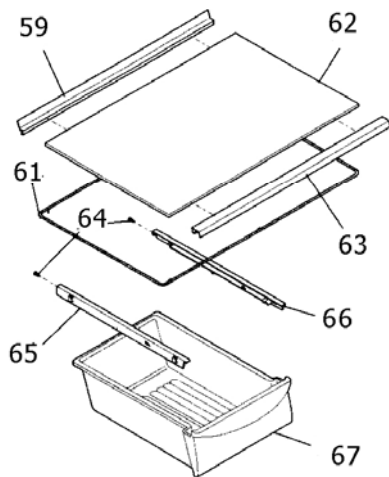

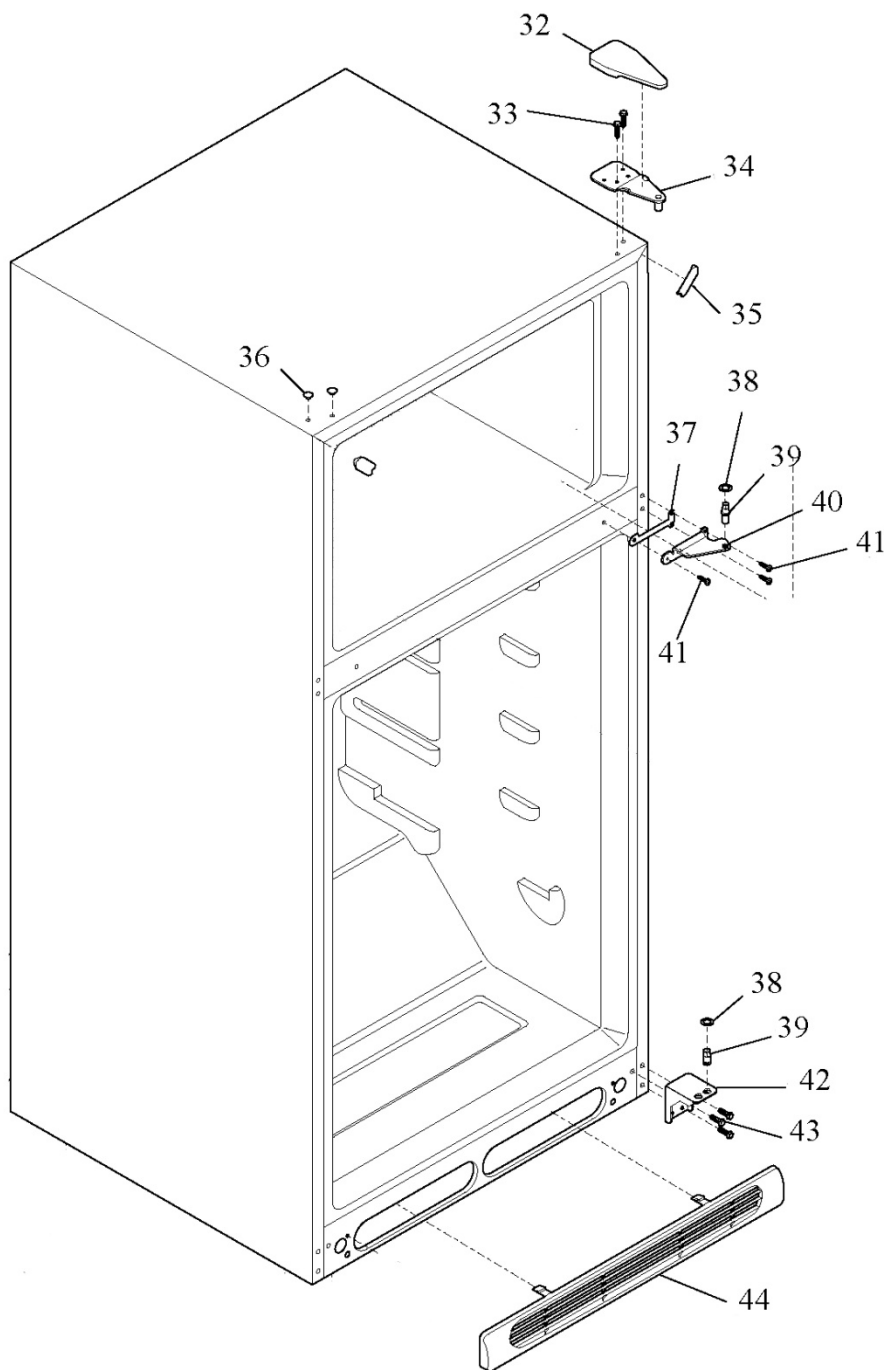

Burner Train Assembly

UGP15

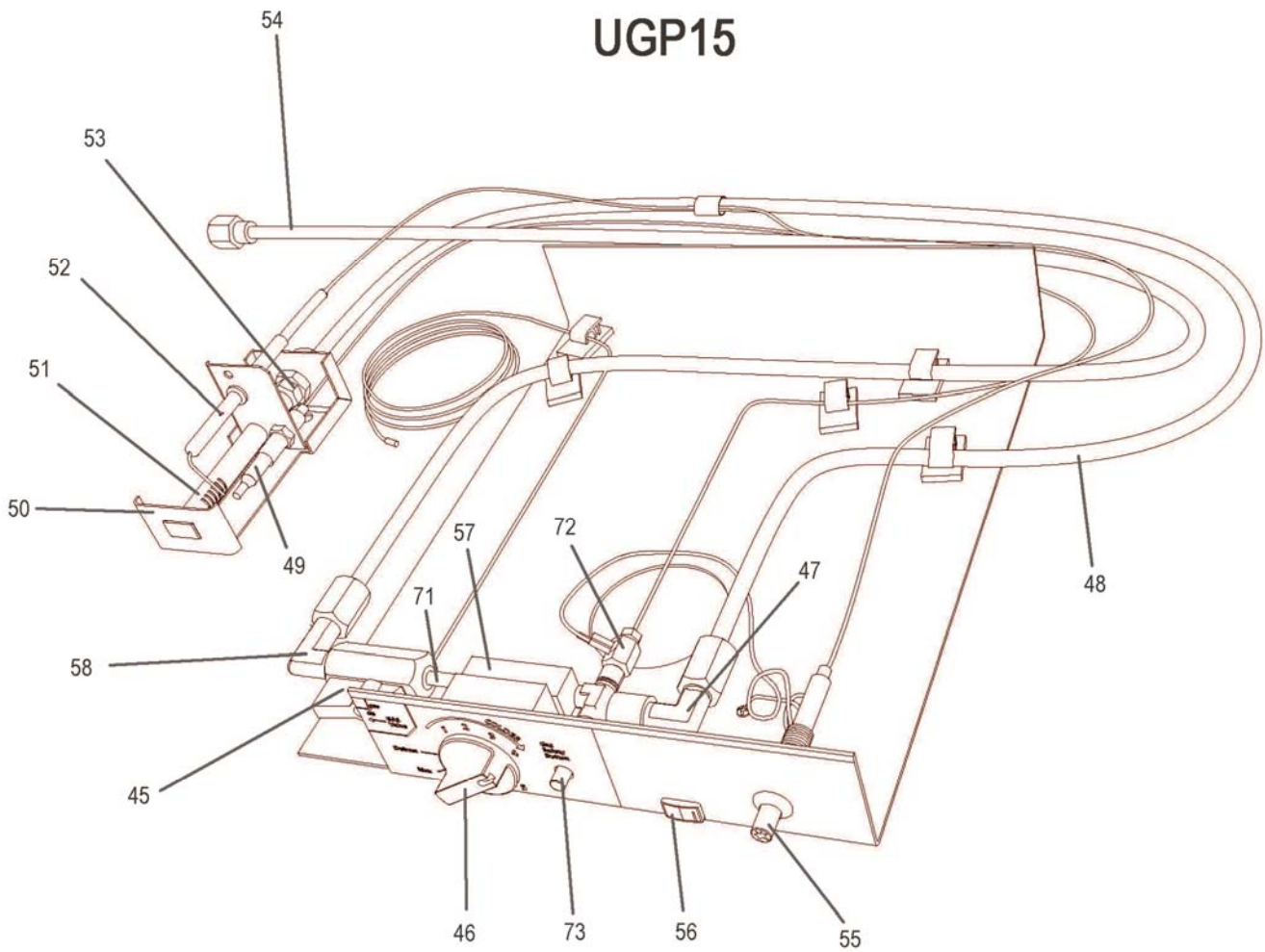

| UNIQUE UGP-15 Fridge (15 cu/ft) | | |
|--|--------------|--|
| Item# | PART# | DESCRIPTION |
| 1 | UGP15-01 | FREEZER DOOR GASKET |
| | UGP15-01-1 | FREEZER DOOR GASKET – BLACK FOR STAINLESS STEEL FRIDGE ONLY |
| 2 | UGP15-02 | PLUG |
| 3 | UGP15-03 | FREEZER DOOR- WHITE |
| | UGP15-03-1 | FREEZER DOOR- STAINLESS STEEL (MUST REQUEST LEFT OR RIGHT HANDED OPENING) |
| 4 | UGP15-04 | CAP |
| 5 | UGP15-05 | HANDLE - SCREW |
| 6 | UGP15-06 | HANDLE - BLOCK |
| 6a | UGP15-06-1 | CAP – HANDLE BLACK FOR STAINLESS STEEL FRIDGE ONLY |
| 7 | UGP15-07 | HANDLE - BUTTON |
| 8 | UGP15-08 | HANDLE - SCREW |
| 9 | UGP15-09 | PLUG |
| 10 | UGP15-10 | DOOR HANDLE - FRIDGE AND FREEZER - WHITE |
| 10a | UGP15-10-1 | DOOR HANDLE - FRIDGE AND FREEZER – BLACK FOR STAINLESS STEEL FRIDGE ONLY |
| 11 | UGP15-11 | FRIDGE DOOR - WHITE |
| | UGP15-11-1 | FRIDGE DOOR -STAINLESS STEEL FOR STAINLESS STEEL FRIDGE ONLY |
| 12 | UGP15-12 | SCREW |
| 13 | UGP15-13 | DOOR STOP – BOTTOM FRIDGE DOOR – WHITE |
| | UGP15-13-1 | DOOR STOP – BOTTOM FRIDGE DOOR – BLACK FOR STAINLESS STEEL FRIDGE ONLY |
| 14 | UGP15-14 | SUPPORT DOOR RACK – RH |
| 15 | UGP15-15 | SUPPORT DOOR RACK – LH |
| 16 | UGP15-16 | DOOR GUARD – 18.65" |

| Item# | PART# | DESCRIPTION |
|-------|------------------------------|--|
| 17 | UGP15-17 | SUPPORT DOOR - RH |
| 18 | UGP15-18 | SUPPORT DOOR - LH |
| 19 | UGP15-19 | DAIRY DOOR |
| | UGP15-19-1 | DAIRY DOOR – CLEAR FOR STAINLESS STEEL FRIDGE ONLY |
| 20 | UGP15-20 | DOOR GUARD – 16.21" |
| 21 | UGP15-21 | FRIDGE – DOOR GASKET |
| | UGP15-21-1 | FRIDGE – DOOR GASKET - BLACK FOR STAINLESS STEEL FRIDGE ONLY |
| 22 | UGP15-22 | DOOR STOP – BOTTOM FREEZER DOOR |
| | UGP15-22-1 | DOOR STOP – BOTTOM FREEZER DOOR - BLACK FOR STAINLESS STEEL FRIDGE ONLY |
| 23 | UGP15-23 | DOOR GUARD - 9.04" |
| 24 | UGP15-24 | INTERIOR LIGHT |
| 25 | UGP15-25 | SWITCH |
| 26 | UGP15-26 | COVER - CRISPER PAN |
| 27 | UGP15-27 | CRISPER DRAWERS |
| 28 | UGP15-28 | WIRE SHELVES |
| 29 | UGP- 9RV-SSO | CO DETECTOR 9RV SSO |
| 30 | QMP- INTERRUPTER BLOCK | INTERRUPTER BLOCK – ONLY USED ON CO-MONITORED FRIDGES |
| 31 | QMP-15-FET | MOSFET ASSY |
| 32 | UGP15-32 | TOP HINGE COVER |
| 33 | UGP15-33 | TOP HINGE SCREWS |
| 34 | UGP15-34 | TOP HINGE |
| 35 | UGP15-35 | CORNER TRIM |

| Item# | PART# | DESCRIPTION |
|-------|-----------|---------------------|
| 36 | UGP15-36 | PLUG – WHITE |
| 37 | UGP15-37 | HINGE SPACER |
| 38 | UGP15-38 | NYLON WASHER |
| 39 | UGP15-39 | PIN – CENTER HINGE |
| 40 | UGP15-40 | CENTER HINGE |
| 41 | UGP15-41 | CENTER HINGE SCREWS |
| 42 | UGP15-42 | BOTTOM HINGE |
| 43 | UGP15-43 | BOTTOM HINGE SCREWS |
| 44 | UGP15-44 | FRONT GRILL |
| 45 | UGP1518-1 | ON/OFF VALVE |
| 46 | UGP1518-2 | THERMOSTAT KNOB |
| 47 | UGP1518-3 | OUTLET FITTING |
| 48 | UGP1518-4 | OUTLET GAS TUBE |
| 49 | UGP15-49 | THERMOCOUPLE |
| 50 | UGP15-50 | BURNER BRACKET |
| 51 | UGP15-51 | BURNER TUBE |
| 52 | UGP15-52 | ELECTRODE WITH WIRE |
| 53 | UGP15-53 | ORIFICE |
| 54 | UGP1518-5 | INLET GAS TUBE |
| 55 | UGP15-55 | PEIZO IGNITOR |
| 56 | UGP15-56 | FLAME INDICATOR |
| 57 | UGP1518-5 | THERMOSTAT CONTROL |

| Item# | PART# | DESCRIPTION |
|-------|------------|---|
| 58 | UGP1518-7 | INLET GAS FITTING |
| 59 | UGP15-59 | TRIM – REAR 16” |
| 60 | UGP15-60 | FRAME - SHELF |
| 61 | UGP15-61 | FRAME - SHELF WITH HANGERTABS |
| 62 | UGP15-62 | GLASS SHELF – NO PATTERN |
| 62 | UGP15-62-1 | GLASS SHELF – PATTERN ON GLASS STAINLESS STEEL UNIT ONLY |
| 63 | UGP15-64 | TRIM - FRONT |
| 64 | UGP15-65 | SCREW – FOR HANGERS STAINLESS STEEL UNIT ONLY |
| 65 | UGP15-65-1 | TRACK – HANGER LH STAINLESS STEEL UNIT ONLY |
| 66 | UGP15-66 | TRACK – HANGER RH STAINLESS STEEL UNIT ONLY |
| 67 | UGP15-67 | MEAT BIN STAINLESS STEEL UNIT ONLY |
| 68 | UGP15-68 | COVER - CRISPER DRAWERS |
| 69 | UGP15-69 | CONTROL – HUMIDITY (NOT FUNCTIONAL ON PROPANE FRIDGES) |
| 70 | UGP15-70 | DAMPER – HUMIDITY CONTROL (NOT FUNCTIONAL ON PROPANE FRIDGES) |
| 71 | UGP1518-8 | PIPE – ON/OFF VALVE TO THERMOSTAT CONTROL |
| 72 | UGPSPBLOCK | SINGLE PRONG INTERRUPTER BLOCK |
| 73 | UGP1518-9 | SAFETY VALVE |

Venting Component Parts List – UGP 15 DV

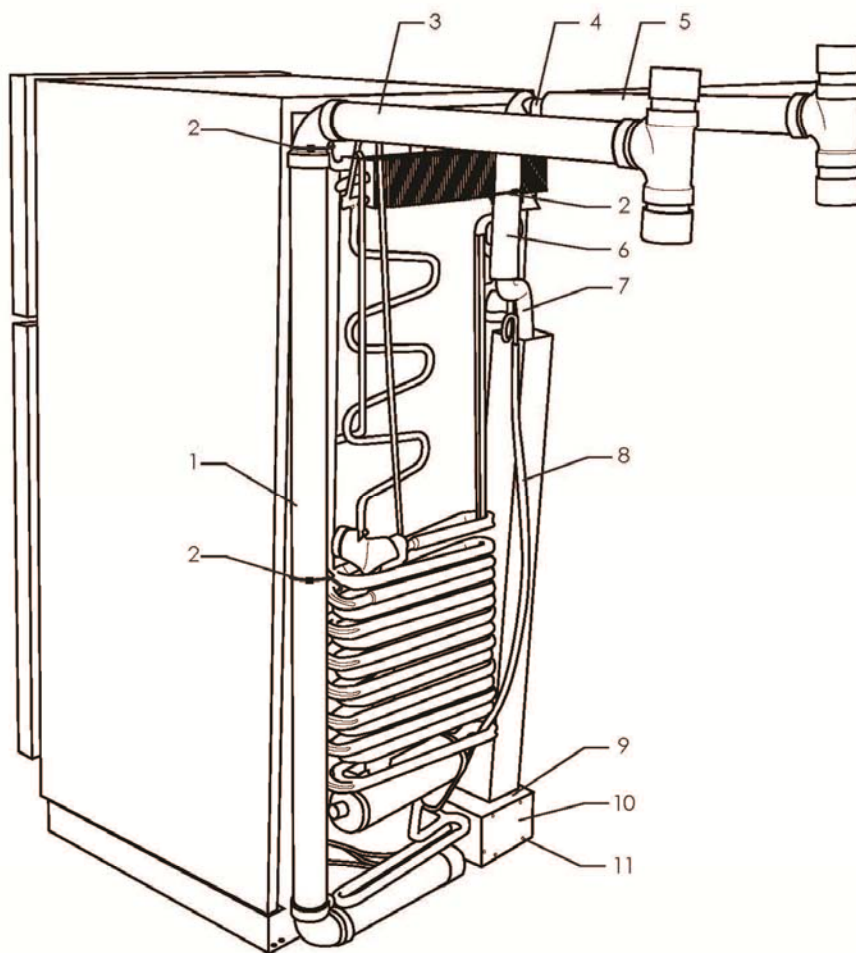

| Unique UGP 15 DV Venting Parts List | | |
|-------------------------------------|--|-----------------------|
| Item # | Description | Part# |
| 1 | <i>Fresh Air Vent Assembly</i> | <i>UGPDV15SA04</i> |
| 2 | <i>Cable Tie</i> | <i>N/A</i> |
| 3 | <i>Fresh Air Exterior Vent Assembly</i> | <i>UGPDV15SA06</i> |
| 4 | <i>90° Elbow (not shown) – part of Chimney Assembly</i> | <i>N/A</i> |
| 5 | <i>Flue Exhaust Vent Assembly</i> | <i>UGPDV15SA05</i> |
| 6 | <i>Chimney Insulation Wrap - part of Chimney Assembly</i> | <i>N/A</i> |
| 7 | <i>Insulated Chimney</i> | <i>UGPDV15SA01</i> |
| 8 | <i>Condensate Hose – 50”</i> | <i>N/A</i> |
| 9 | <i>Burner Box Assembly</i> | <i>UGPDV15SA02</i> |
| 10 | <i>Burner Box Lid Assembly includes Screws</i> | <i>UGPDV15SA03</i> |
| 11 | <i>Cover Plate Screws – Part of Burner Box Lid Assembly</i> | <i>N/A</i> |
| Misc Parts | | |
| <i>Not shown</i> | <i>Silicone – High Temp – seals fresh air and flue connections</i> | <i>UGP-HTSilicone</i> |



UNIQUE UGP15

5 YEAR LIMITED WARRANTY*

Unique Gas Products Ltd. warrants that this UNIQUE refrigerator is free from defects in material and workmanship under normal usage and service under the following terms:

1. This Warranty is made only to the first purchaser ("original purchaser") who acquires this refrigerator for his/her own use and will be honored by **Unique Gas Products Ltd.** and by the Seller.
2. Any part of this refrigerator returned to the Seller or **Unique Gas Products Ltd.**, which upon examination is determined by them to have been defective in material or workmanship, will at their option be either repaired or replaced under this warranty, without charge for materials/parts. (customer is responsible for labour)
3. The obligation to repair or replace defective parts will apply only to parts returned within one year of the date of purchase and will constitute the Sellers sole obligation under this Warranty. The cooling system (coil) is warranted for a total of five years and will be replaced at no charge by **Unique Gas Products Ltd.** and the Seller (labour and transportation charges will be the responsibility of the owner). Coils replaced during the initial five-year period will be warranted only for the remaining portion.

The Seller will have no obligation under this warranty with respect to conditions unrelated to the material or workmanship of this refrigerator. Such unrelated conditions include without limitation:

- a) faulty installation (or venting) and damage resulting therefrom; not installed by Seller
- b) the need for normal maintenance of this refrigerator (including the cleaning of the Burner, Venturi, orifice, flue tubes and assurance of proper propane gas pressure);
- c) any accidents to or misuse of any part of this refrigerator and any alteration thereof by anyone other than the Seller or its authorized representative.

This UNIQUE Refrigerator **must** be serviced regularly as outlined in the Owner's Manual. **Unique Gas Products Ltd.** the seller will not be liable for direct or indirect loss of foods caused by failure in operation. In case of damage, the owner must provide proof of purchase, Model, and Serial Number to the Seller or **Unique Gas Products Ltd.**

*Due to remote locations, it is the customer's responsibility to bring items to dealer for review.

Please fill out warranty card within 30 days and mail back for warranty coverage